

TECHNICAL MANUAL

**TRANSPORTABILITY GUIDANCE
CARRIER, CARGO, M973, 1-1/2-TON
(NSN 2350-01-132-9099)
SMALL UNIT SUPPORT VEHICLE (SUSV)**



**TRANSPORTABILITY GUIDANCE
CARRIER, CARGO, M973, 1-1/2-TON
(NSN 2350-01-132-9099)
SMALL UNIT-SUPPORT VEHICLE (SUSV)**

		Paragraph	Page
CHAPTER	1. INTRODUCTION		
	Purpose and Scope.....	1-1	1-1
	Reporting of Recommendations and Comments	1-2	1-1
	Safety	1-4	1-1
	Definitions of Warnings, Cautions, and Notes	1-4	1-1
	2. TRANSPORTABILITY DATA		
	Scope	2-1	2-1
	Description.....	2-2	2-1
	General.....	2-3	2-1
	Reduced Configuration	2-4	2-1
	Unusual Characteristics	2-5	2-1
	Hazardous and Dangerous Characteristics.....	2-6	2-2
	General Transportability Characteristics.....	2-7	2-2
	3. SAFETY		
	General.....	3-1	3-1
	Specific Safety Requirements.....	3-2	3-1
CHAPTER	4. AIR TRANSPORTABILITY GUIDANCE		
SECTION	I. GENERAL		
	Scope	4-1	4-1
	Maximum Utilization of Aircraft	4-2	4-1
	Safety	4-3	4-1
	II. TRANSPORT BY US ARMY HELICOPTER		
	Transport by US Army Helicopter	4-4	4-1
	III. TRANSPORT BY US AIR FORCE AIRCRAFT		
	Transport by US Air Force Aircraft	4-5	4-2
	Tiedown Diagrams and Tables	4-6	4-2
CHAPTER	5. HIGHWAY TRANSPORTABILITY GUIDANCE		
SECTION	I. GENERAL		
	Scope	5-1	5-1
	Safety	5-2	5-1
	General.....	5-3	5-1
	II. TRANSPORT BY SEMITRAILER		
	Preparation	5-4	5-1
	Transport on M127A1 Semitrailer.....	5-5	5-1
	Transport on M172A1 Semitrailer.....	5-6	5-6
CHAPTER	6. MARINE AND TERMINAL TRANSPORTABILITY GUIDANCE		
SECTION	I. GENERAL		
	Scope	6-1	6-1
	Safety	6-2	6-1
	Marine Shipment.....	6-3	6-1
	II. LOADING AND SECURING		
	General Rules.....	6-4	6-1
	General Cargo and Barge-Type (LASH or SEABEE) Ship.....	6-5	6-2
	Roll-On/Roll-Off (RORO) and Seatrains Vessels, Landing Ships,	6-6	6-5
	and Attack Cargo Ships		

		Paragraph	Page
CHAPTER 7.	RAIL TRANSPORTABILITY GUIDANCE		
SECTION I.	GENERAL		
	Scope	7-1	7-1
	Maximum Utilization of Railcars.....	7-2	7-1
II.	TRANSPORT ON CONUS RAILWAYS		
	General.....	7-3	7-1
	Preparation	7-4	7-1
	Loading on General Purpose Flatcars	7-5	7-1
III.	TRANSPORTATION ON FOREIGN RAILWAYS		
	General.....	7-6	7-4
	Transport on Foreign Service Flatcars	7-7	7-4
APPENDIX		A-1

CHAPTER 1 INTRODUCTION

1-1. Purpose and Scope

This manual provides transportability guidance for logistical handling and movement of the carrier, cargo, 1½-ton (referred to hereinafter as M973). It provides transportation officers, down to division level, and other personnel engaged in or responsible for movement or providing transportation services with information considered appropriate for safe transport. Significant technical and physical characteristics, as well as safety considerations, required for worldwide movement by the various modes of transportation are included. When considered necessary, metric equivalents are given in parentheses following dimensions or other measurements.

1-2. Reporting of Recommendations and Comments

The reporting of errors, omissions, and recommendations for improving this manual by the individual user is encouraged. Reports should be submitted on DA Form 2028 (Recommended Changes to DA Publications and Blank Forms) and forwarded direct to Commander, Military Traffic Management Command Transportation Engineering Agency, ATTN: MTT-TRC, PO Box 6276, Newport News, Virginia 23606-0276. Electrically transmitted messages should be addressed to CDR MTMC TEA FT EUSTIS VA//MTT-TRC//. A reply will be furnished by this command.

1-3. Safety

Appropriate precautionary measures required during movement of the vehicle are contained in chapter 3.

1-4. Definitions of Warnings, Cautions, and Notes

Throughout this manual, warnings, cautions, and notes emphasize important or critical guidance. They are used for the following conditions:

- a. *Warning.* An operating procedure or practice that, if not correctly followed, could result in personal injury or loss of life.
- b. *Caution.* An operating procedure or practice that, if not strictly observed, could result in damage to or destruction of equipment.
- c. *Note.* An operating procedure or condition that must be emphasized.

CHAPTER 2 TRANSPORTABILITY DATA

2-1. Scope

This chapter provides a general description of the M973, identification photographs, and tabulated transportability characteristics and data that are necessary for movement of this vehicle.

2-2. Description

The M973 is a full-tracked, self-propelled, articulated vehicle with drive on all four tracks. It is powered by a diesel engine with a fully automatic gearbox. The M973 can be transported by helicopter, ship, rail, highway, and cargo aircraft.

2-3. General

The M973 cargo carrier is illustrated in figure 2-1. Side and rear elevation drawings (figs 2-2 and 2-3) provide data necessary for determining the loadability of the M973 for movement by various transportation modes.

2-4. Reduced Configuration

Transportation economies can be obtained by reducing the carrier to the minimum dimensions for terminal handling and ocean transport. The only items that are readily removable are the radio antenna and winch, which should be shipped inside the cab of the M973.

2-5. Unusual Characteristics

The M973 carrier is an articulated vehicle. Before the carrier can be lifted by sling, care must be used to insure that the steering cylinders are locked. There are no other unusual characteristics requiring that special attention be given to temperature, atmospheric pressure, or humidity variations during exposure to normal transportation environments.



Figure 2-1. The M973 cargo carrier.

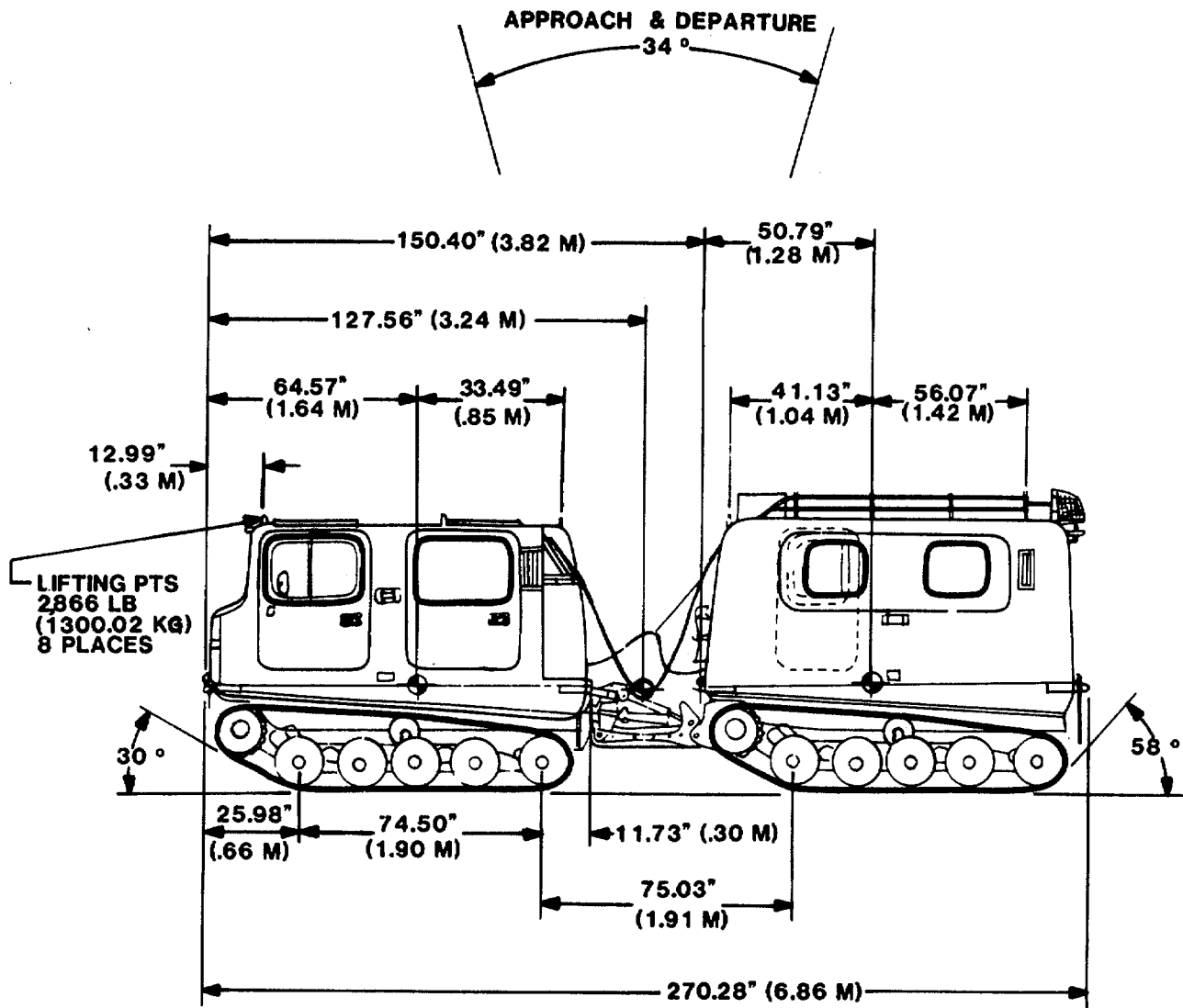

Figure 2-2. Side elevation of the M973 cargo carrier.

2-6. Hazardous and Dangerous Characteristics

The M973 does not present any hazardous or dangerous characteristics during exposure to normal transportation environments.

2-7. General Transportability Characteristics

Carrier, Full-Track, M973

- National stock number2350-01-132-9099
- Line item number C11280
- Ground pressure
 - Unloaded (curb weight) 1.3 psi
(0.09 kg/cm²)
 - Loaded 1.8 psi (0.125 kg/cm²)
- Ground contact area 55.8 ft² (5.17 m²)
- Track type.....molded rubber with cord
 - Width.....24.43 in. (0.62 m)
- Axleload..... NA

Body glass-fiber reinforced plastic (GRP)

Performance

- Maximum speed (roads) ...31 mph (50 km/h)
- (in water) 2 mph (3 km/h)
- Maximum grade (hard surface).....60% (31°)
- Maximum side slope.....90% (42°)
- Cruising range200 mi (330 km)
- Fuel tank capacity..... 42.2 gal (159.7 liters)
- Fuel type diesel
- Turning 26 ft (8.0 m)
- Angle of approach34°
- Angle of departure34°
- Ground clearance13.78 in. (0.35 m)

Dimensions and shipping data; operational (not reducible)

Length, operational
(w/o winch)270.16 in. (6.86 m)

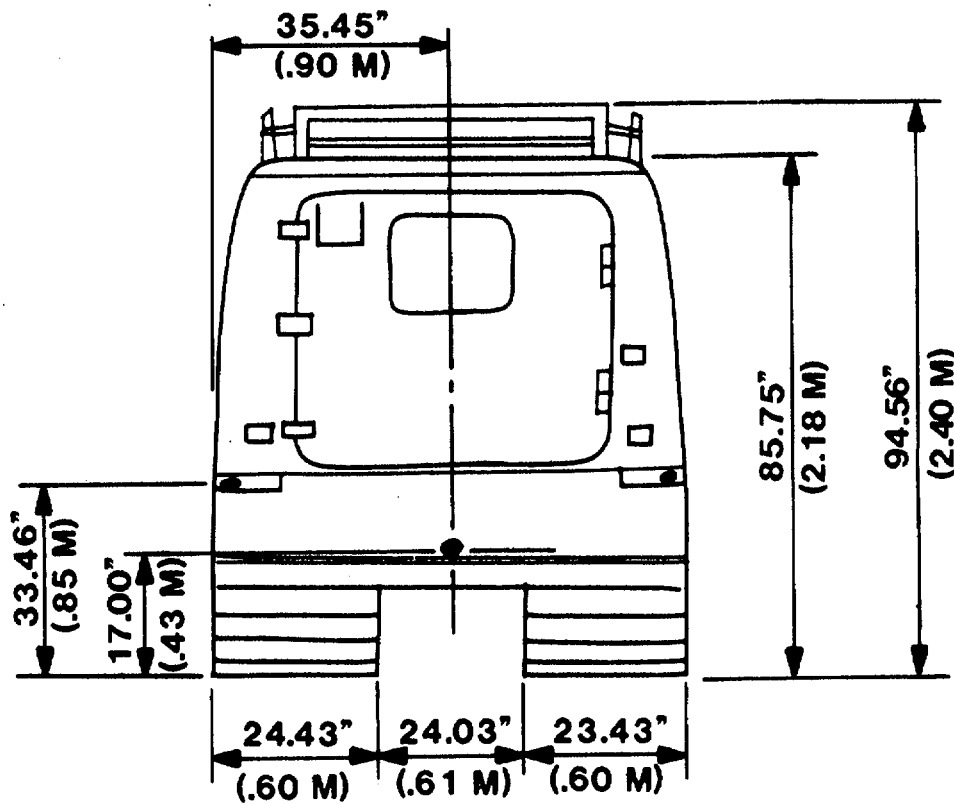

Figure 2-3. Rear elevation of the M973 cargo carrier.

Width, operational (w/o mirrors)	72.83 in. (1.85 m)	Above ground.....	35.4 in. (0.90 m)
Height, operational (w/o antenna mounts)	94.48 in. (2.40 m)	From centerline of rear car drive sprocket	41.54 in. (1.06 m)
Cube, operational.....	1,081 cu ft (30.6 cum)	Combined:	
Width between tracks.....	24.03 in. (0.61 m)	Above ground.....	35.4 in. (0.90 m)
Center of gravity		From centerline of front car drive sprocket	107.8 in. (0.51 m)
Front car:		Pintle height	20.0 in. (0.51m)
Above ground.....	35.4 in. (0.90 m)	Shipping weight	
From centerline of front car drive sprocket	54.13 in. (1.37 m)	Front car.....	6,416 lb (2 910 kg)
Rear car:		Rear car	3,684 lb (1 671 kg)
		Total.....	10,100 lb (4 581 kg)

**CHAPTER 3
SAFETY**

3-1. General

General safety considerations and precautions for handling and movement of the M973 are as follows:

- a. Check to insure that all loose items are properly secured.
- b. When backing the vehicle, insure that a ground guide is provided and that no personnel or obstacles are between cars or behind the M973.
- c. Check to insure that lifting eyes are screwed all the way in (shoulder flush with roof of vehicle) and cannot be loosened by hand.

WARNING

Fire extinguishers must be readily available during all loading and unloading operations.

WARNING

Proper ventilation must be provided during loading and unloading operations if carrier engine is operated. Prolonged inhalation of exhaust fumes could be fatal.

WARNING

Steering cylinders are not to be used for tiedown or lift purposes.

3-2. Specific Safety Requirements

Pertinent safety requirements by individual modes of transport can be found in the appropriate chapters.

**CHAPTER 4
AIR TRANSPORTABILITY GUIDANCE**

Section I. GENERAL

4-1. Scope

This chapter provides air transportability guidance for movement of the M973. Examples of tiedown diagrams and tie-down data for loading this vehicle into US Air Force C-130, C-141, and C-5 aircraft are presented, as well as procedures for transport by US Army CH- 54A/B and CH-47C/D helicopters.

4-2. Maximum Utilization of Aircraft

Additional cargo, including nuclear weapons and/or personnel, within allowable load limits and restrictions as prescribed by pertinent safety regulations (app), can be transported with the M973 in US Air Force aircraft.

4-3. Safety

In addition to the safety precautions in chapter 3, the following procedures apply:

- a. The activity offering the vehicle for air transport will notify the aircraft commander or his/her representative when ammunition or explosives are to be transported in the vehicle.
- b. The vehicle fuel tanks must not be more than three-fourths full.
- c. The required number of tiedowns plus their capacity must be checked and the criteria for gravity forces adhered to in accordance with procedures in section IV of Air Force TO 1C-130A-9, TO 1C-141B- 9, and TO 1C-5A-9. Procedures outlined in this manual are for general guidance.

CAUTION

Do not allow the carrier to exceed 3 miles per hour on the loading ramps or inside the aircraft.

Section II. TRANSPORT BY US ARMY HELICOPTER

4-4. Transport by US Army Helicopter

- a. Applicability. This load is suitable for the CH- 54A/B and CH-47C/D helicopters at speeds of 70 knots.
- b. Load Description
 - (1) Carrier, M973, all-terrain, full-tracked, with articulated steering.
 - (2) Weight:

Carrier	10,100 pounds
Accompanying load	3,000 pounds
Total.....	13,100 pounds
- c. Materials.
 - (1) Two sling sets, helicopter, cargo-carrying, external (25,000-lb-capacity), NSN 1670-01-017-2900.
 - (2) Four chains with connector links (25,000-lb- capacity), NSN 4010-01-058-4772.
 - (3) Coupling link, P/N 664241.
 - (4) Cord, nylon, type III, 550-pound breaking strength.
 - (5) Tape, adhesive, pressure-sensitive, 2-inch-wide roll.
 - (6) Grounding rod, locally fabricated.
- d. Personnel. Two personnel can prepare and rig the load in 35 minutes.
- e. Preparation.
 - (1) Secure all internal cargo and loose items with nylon rope.
 - (2) Lock the articulated steering unit with the steering cylinder locks.
 - (3) Secure all doors, windows, and roof hatches in the closed position.
 - (4) Check to insure that lifting eyes are screwed all the way in (shoulder flush with the roof of the vehicle) and cannot be loosened by hand.
- f. Rigging.
 - (1) Assemble the two sling sets as shown in figure 4-1. Note the sling leg numbering sequence.
 - (2) Loop the chain end of sling legs 5 and 6 through the aft lifting provisions of the front car of the carrier and insert link 8 in the grabhooks.
 - (3) Loop the chain end of sling legs 7 and 8 through the forward lifting provisions of the rear car of the carrier and insert link 11 in the grabhooks.
 - (4) Loop the chain end of sling legs 1 and 2 through the forward lifting provisions of the front car. Attach an additional chain to the No. 1 link on the chain legs with the connector link. The chain leg must be looped through the lifting provision prior to attaching the additional chain. Insert link 14 of the additional chain in the grabhook.
 - (5) Loop the chain end of sling legs 3 and 4 through the aft lifting provisions of the rear car. Attach an additional chain the same as for sling legs 1 and 2. Insert link 18 of the additional chain leg in the grabhook.
 - (6) Tape the loose ends of the chain legs.
 - (7) If the carrier has to be driven after being pre- pared for helicopter lift, secure the slings and clevis

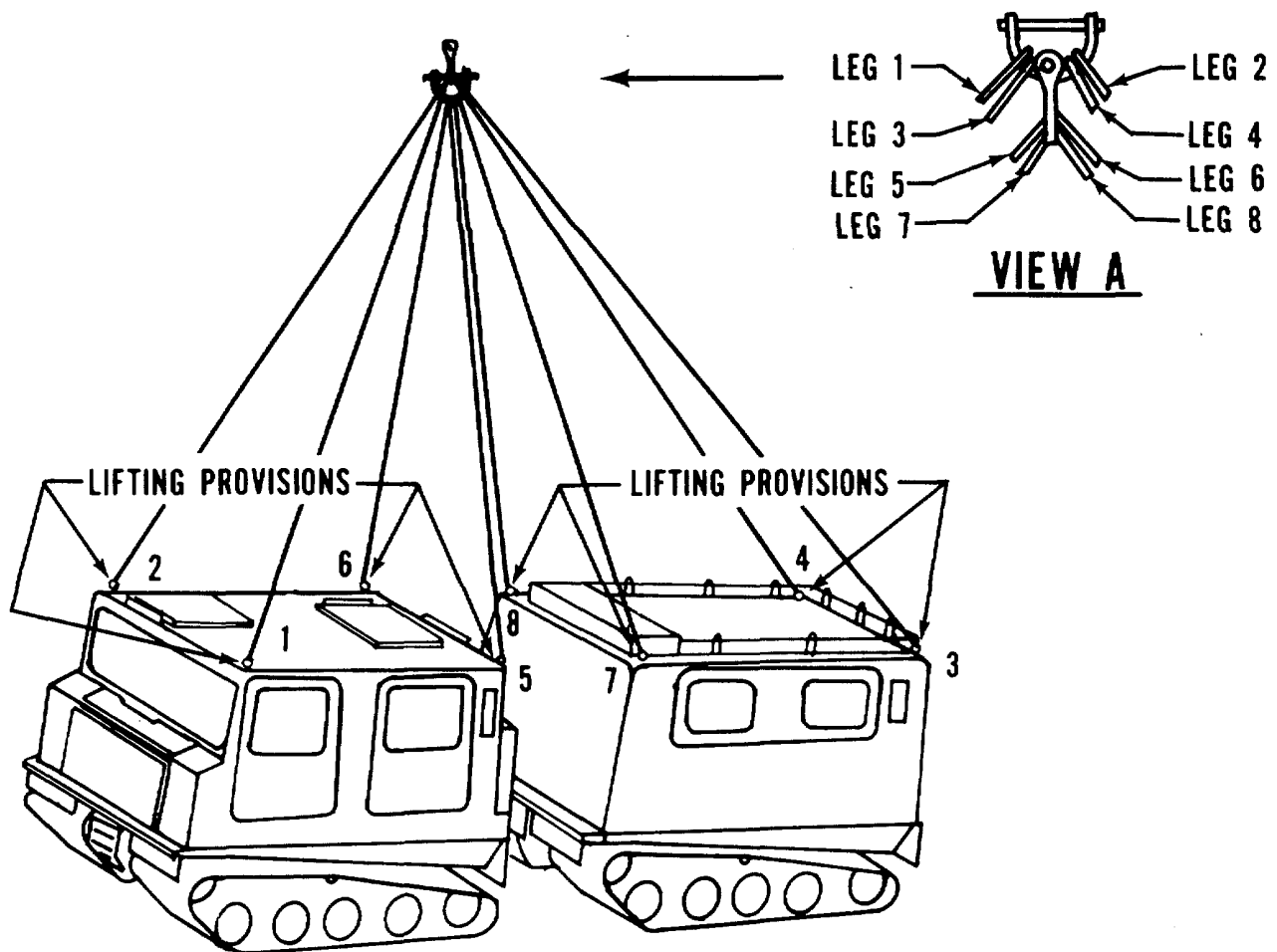

Figure 4-1. Sling diagram for transport of the M973 by helicopter

by gathering them together on the roof of the rear car and tie with nylon cord, Type III.

CAUTION

Remove the nylon cord prior to the helicopter lift.

g. Hookup.

(1) For normal operations, two persons are required to perform the hookup. Both persons stand on the top of the rear car. One person places the sling clevis in the cargo hook and the other person grounds

the cargo hook with the grounding rod and provides assistance to the person performing the hookup.

(2) Both hookup persons depart from the load to the side of the aircraft. They observe the sling legs to insure that they are not crossed, tangled, or snagged on the carrier as it is lifted.

(3) For operations during blinding conditions (extreme dust or snow), a pendant is required. Prior to lifting under these conditions, the unit SOP or the unit pathfinder must be consulted for the proper length and type of pendant and the procedures to be used.

Section III. TRANSPORT BY US AIR FORCE AIRCRAFT

4-5. Transport by US Air Force Aircraft

The M973 is transportable by the C-130, C-141, and C-5 aircraft. The aircraft commander or his/her representative is responsible for insuring that the vehicle is loaded or unloaded and properly secured in the aircraft in accordance with the criteria in section IV of the appropriate technical order.

4-6. Tiedown Diagrams and Tables

Figures 4-2 and 4-3 are diagrams for tiedown of the M973 in C-130, C-141, and C-5 aircraft. Tables 4-1 and 4-2 are applications of the tiedowns in C-130, C-141, and C-5 aircraft.

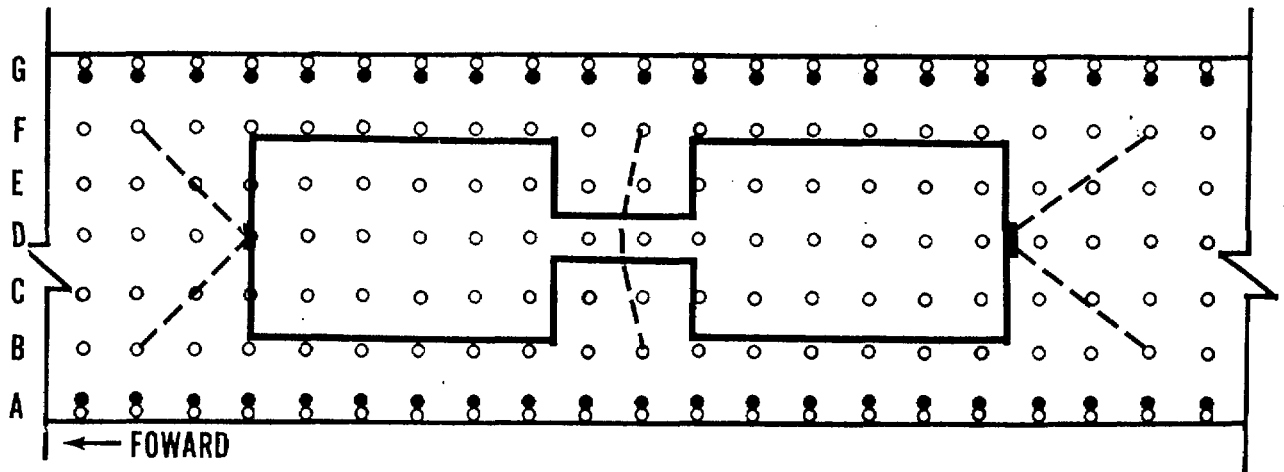

SYMBOL	○	●
STRENGTH OF FITTING AND BASIC LOAD DIRECTION	10,000 LB ANY	25,000 LB ANY

Figure 4-2. Tiedown diagram of the M973 in C-130 or C-141 aircraft.

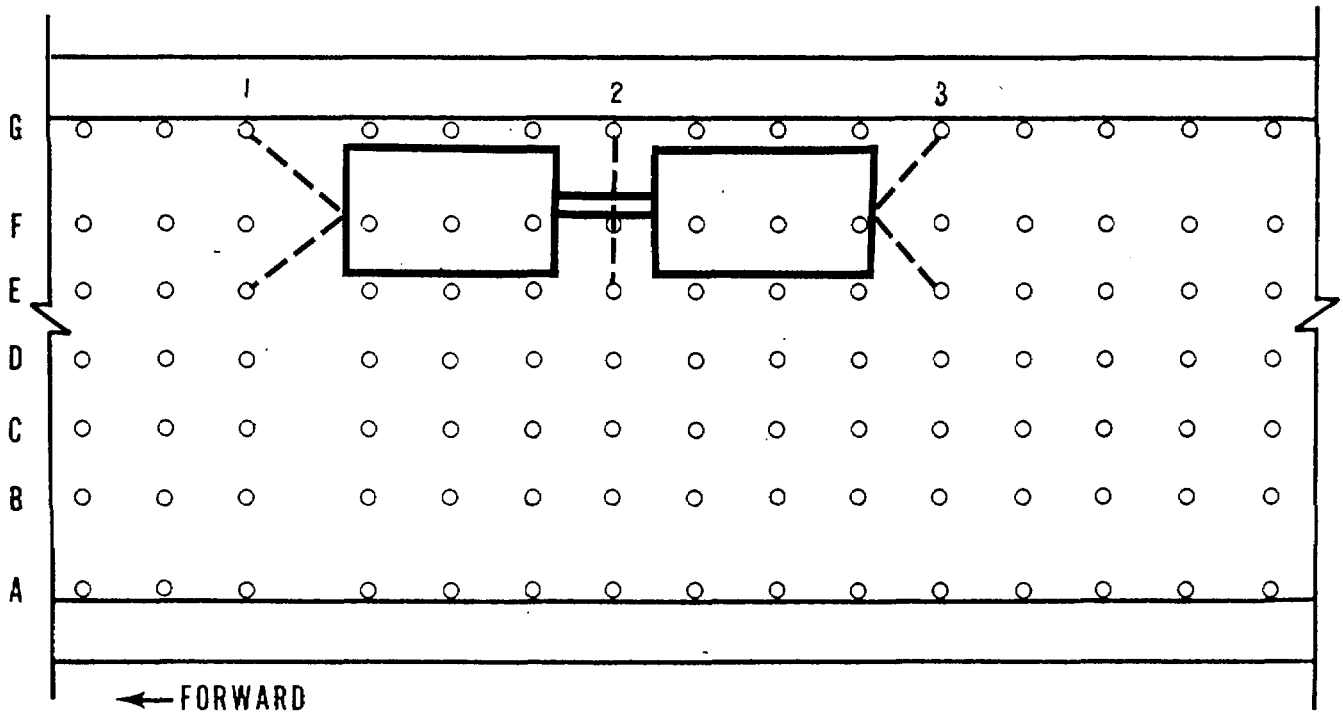

○ ALL CARGO TIEDOWN FITTING RATINGS 25,000 LB EACH

Figure 4-3. Tiedown diagram of the M973 in C-5 aircraft

CAUTION

Tension tiedowns evenly. Do not exceed 400 pounds of tension on any single tiedown.

NOTE

The M973 is backed into the aircraft. Once it is positioned in the aircraft, the articulated steering unit must be locked with the steering cylinder locks.

Table 4-1. Tiedown of the M973 in C-130 or C-141 Aircraft.

Designation	Tiedown Fitting		Tiedown Device		Attach to Item
	Capacity in 1,000 lb	Type	Capacity in 1,000 lb	Type	
C1	10	MB1	10		Rear pintle
E1	10	MB1	10		Rear pintle
C2	10	MB1	10		Over lower support arms to E2 (use cushioning material between chain and support arms)
B3	10	MB1	10		Loop around left end of towing provision
F3	10	MB1	10		Loop around right end of towing provision.

Table 4-2. Tiedown of the M973 in. C-5 Aircraft.

Designation	Tiedown Fitting		Tiedown Device		Attach to Item
	Capacity in 1,000 lb	Type	Capacity in 1,000 lb	Type	
E1	25	MB1	10		Rear pintle
G1	25	MB1	10		Rear pintle
E2-G2	25	MB1	10		Over lower support arms to G2 (use cushioning material between chain and lower support arm)
E2	25	MB1	10		Loop around left end of towing provision
G2	25	MB1	10		Loop around right end of towing provision

CHAPTER 5 HIGHWAY TRANSPORTABILITY GUIDANCE

Section I. GENERAL

5-1. Scope

This chapter provides transportability guidance for highway movement of the M973. It covers significant technical and physical characteristics as well as safety precautions; prescribes materials; and provides guidance required to prepare, load, tie down, and unload the M973.

5-2. Safety

a. In addition to the safety precautions in chapter 3, movement of the system within CONUS is subject to all safety laws, rules, and regulations applicable to commercial carriers. Overseas movements are governed by theater and local regulations.

b. Lifting of the M973 is discussed in paragraph 6-3.

5-3. General

The M973 is self-deliverable only under appropriate tactical situations. Movement over paved public highways will not be made without specific approval as outlined in AR 55-162. Legal limitations for overseas are identified in "Limits of Motor Vehicle Sizes and Weights," International Road Federation, Geneva, Switzerland.

Section II. TRANSPORT BY SEMITRAILER

5-4. Preparation

Remove all basic issue items from the outside of the M973 and stow them securely inside the M973 to preclude damage during transport.

WARNING

Other than the M973 driver, no one is allowed on the semitrailer at any time during loading operations.

WARNING

Loading must not be conducted on side or lateral slopes exceeding 10 percent or with a tractor-to-trailer offset angle greater than 5°. Also, loading on a severe downgrade must be avoided to prevent the payload from rolling forward on the trailer.

5-5. Transport on M127A1 Semitrailer

a. *General.* Figures 5-1 and 5-2 show the M973 loaded on the M127A1 semitrailer. Figure 5-3 shows details of blocking and tiedown materials used to restrain the M973 on the semitrailer.

b. *Materials.* Adequate blocking and tiedown materials are provided by the shipping activity and are listed in table 5-1. Table 5-2 provides application of materials for blocking and tiedown of the M973 on the M127A1 semitrailer.

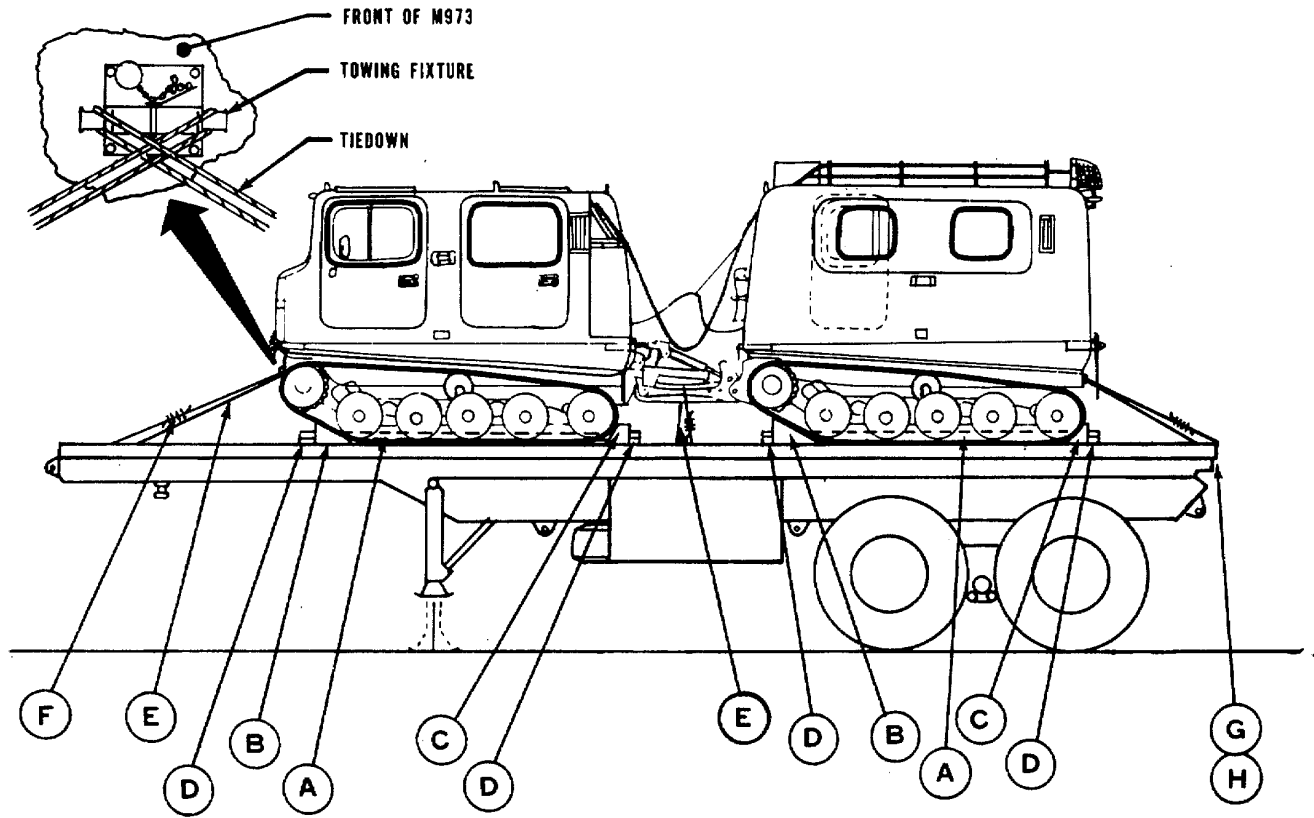

Figure 5-1. Side elevation, tiedown of the M973 on the M127A1 semitrailer

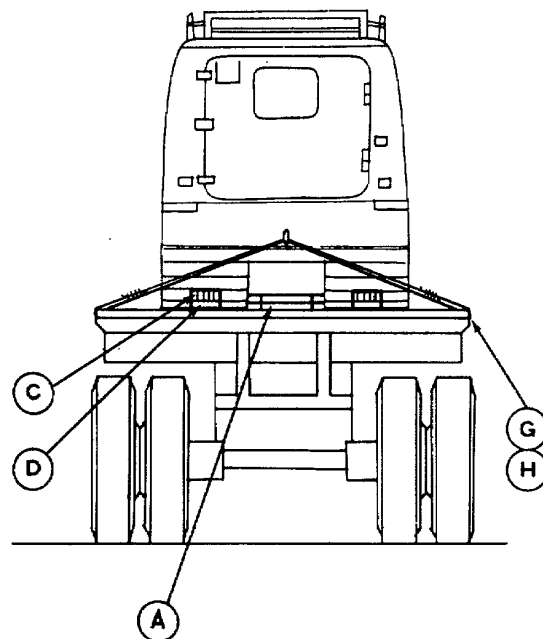

Figure 5-2. End elevation, tiedown of the M973 on the M127A1 semitrailer.

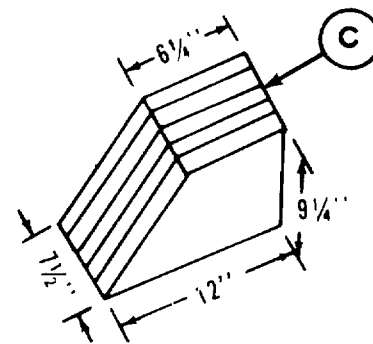
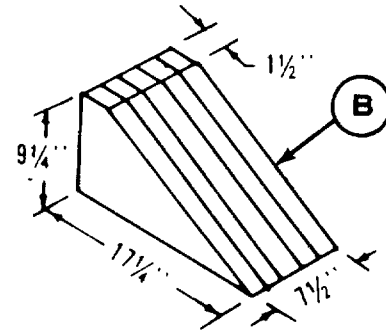
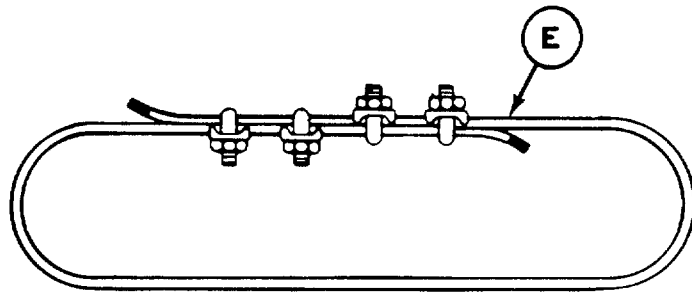
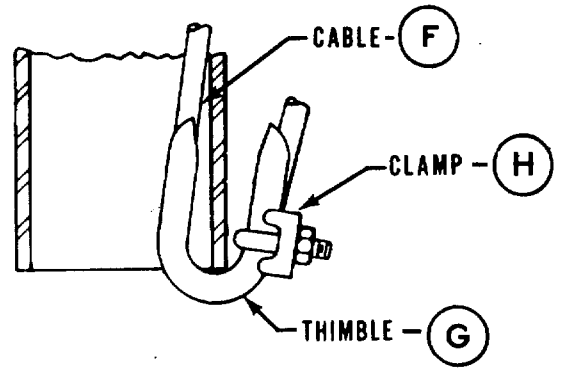
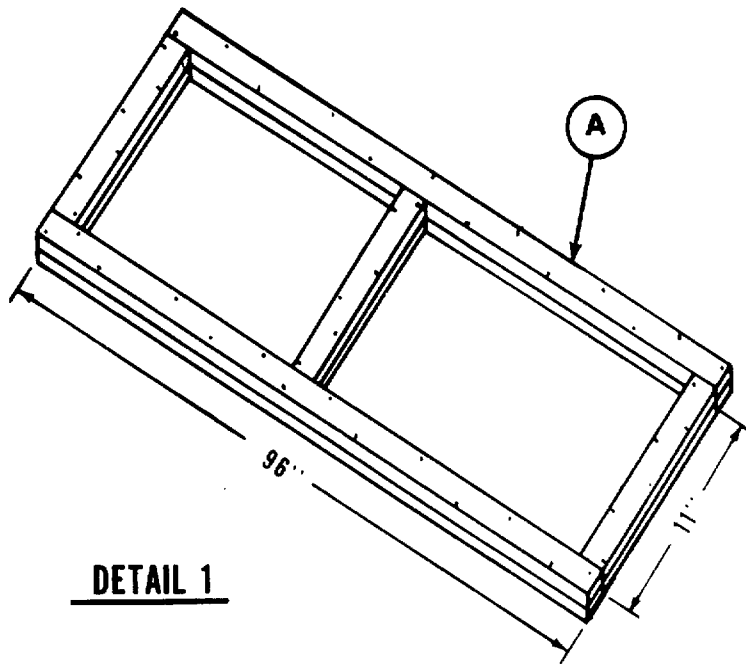

Figure 5-3. Blocking and tiedown details

Table 5-1. Bill of Materials for Blocking and Tiedown of the M973 on the M127A1 Semitrailers (Figs 5-1, 5-2, and 5-3).

Item	Description	Approximate Quantity
Lumber	Douglas-fir or comparable, straight-grain free from material defects; Fed Spec MM-L-751: 2- x 4-inch 2- x 6-inch 2- x 10-inch	2 linear ft 100 linear ft 40 linear ft
Nails	Common, steel; flathead, bright or cement-coated, type II, style 10; Fed Spec FF-N-105:12d 20d	270 100
Wire rope*	6 x 19 IWRC; improved plow steel; preformed, regular-lay; table X, Fed Spec RR-W-410: 1/2-inch	130 ft
Clamps*	Wire rope, U-bolt clips, saddled, single-grip, forged steel, Crosby heavy-duty or equal; Fed Spec FF-C-450: 1/2 inch 5/8-inch	20 6
Thimbles*	Standard, open-type, 1/2-inch	6

*Chains and loadbinders may be substituted.

Table 5-2. Application of Material for Blocking and Tiedown of the M973 on the M127A1 Semitrailer (Figs 5-1, 5-2, and 5-5).

Item No.	Required	Application
A	2	H-frame bracing (detail 1, fig 5-3). Each layer consists of three pieces of 2- x 6- x 11-inch lumber and two pieces of 2- x 6- x 96-inch lumber. Place the first piece of 11-inch lumber 70 inches from the forward end of the trailer with one end 5.5 inches from the centerline of the trailer. Nail to the trailer with four 12d nails. Place the second piece (centered) 4 feet from the forward side of the first piece. Place the third piece so that the aft edge is 8 feet from the forward edge of the first piece. Nail each with four 12d nails. Place one piece of 96-inch lumber against the ends of the 11- inch pieces and nail each with sixteen 12d nails. Repeat for the second layer, except nail with 20d nails. Build the second H-frame so that the forward end is 38 inches from the aft end of the forward H-frame. Load the M973.
B	4	Forward track chocks (detail 4, fig 5-3). Each consists of five pieces of 2- x 10-inch lumber nailed together with 12d nails. Place one chock firmly against each track at the forward end of each unit. Toenail with three 20d nails in each side.
C	4	Rear track chocks (detail 5, fig 5-3). Each consists of five pieces of 2- x 10-inch lumber nailed together with 12d nails. Place one chock firmly against each track at the rear end of each unit. Toenail with three 20d nails in each side.
D	8	Backup cleats. Use two pieces of 2- x 6- x 12-inch lumber. Place against the heel of each track chock, items B and C. Nail the bottom piece with four 12d nails and the top piece with four 20d nails.
E*	8	Wire rope (detail 3, fig 6-3). Each consists of 1/2-inch wire rope, length as required. Form a complete loop between the front units' forward tiedown fixtures and the right stake pocket. Form a complete loop between the front units' forward tiedown fixtures and the left stake pocket. Place one complete loop from the left stake pocket over the lower support arms, between the units, to the right stake pocket. Secure a 2- x 4- x 10-inch wooden block between the wire rope and each support arm so that the wire rope does not contact the support arms when wire is tensioned. Form one complete loop between the rear units' pintle and the right stake pocket. Form a complete loop between the rear units' pintle and the left stake pocket, tension all tiedowns evenly. CAUTION Tension tiedowns evenly. Do not exceed 400 pounds of tension on any single tiedown. (Wire rope ends should overlap a minimum of 20 inches.) Secure with four 1/2-inch clamps (item F).
F*	32	Clamps, 1/2-inch (detail 3, fig 5-3). Place four clamps on each wire rope loop at the overlap area. Space the four clamps 2 1/2 inches apart, with a minimum of 6 inches from the free end of the wire rope. Tension wire rope and tighten clamps from 20- to 25-foot-pound torque.
G*	6	Thimbles, 1/2-inch (detail 2, fig 53). Place a thimble between the wire rope and the stake pocket and secure with item H.
H*	6	Clamps, 5/16-inch (detail 2, fig 5-3). Secure each 1/2-inch thimble with one clamp.

*Chains and loadbinders may be substituted.

c. *Loading.* The M973 may be placed in the tiedown position on a semitrailer by a crane of adequate capacity (5-ton minimum), or it may be driven onto the semitrailer provided that a suitable ramp is available. When the M973 is in the tiedown position, the transmission control must be placed in neutral. Parking brakes must be set.

d. *Tiedown.* Figures 5-1, 5-2, and 5-3 show the M973 tied down, in accordance with standard loading practices, so the load will be adequately restrained against forces encountered at normal speeds and operating conditions.

e. *Turning Diagram.* Figure 5-4 is a turning diagram for the M127A1 semitrailer towed by the M818 truck-tractor.

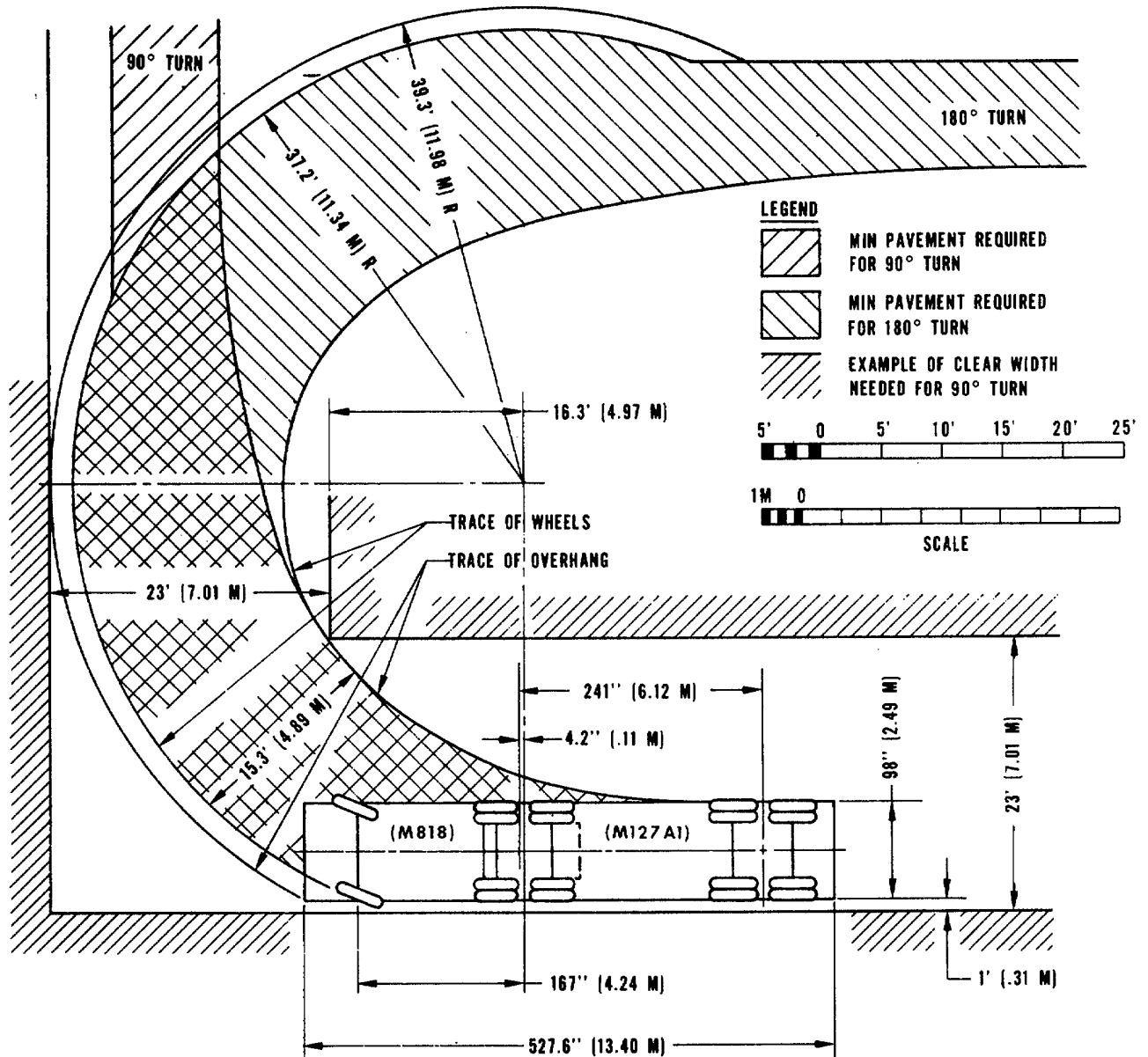

Figure 5-4. Turning diagram for the M127A1 semitrailer towed by the M818 truck-tractor.

5-6. Transport on M172A1 Semitrailer

- a. *General.* Figures 5-5, 5-6, and 5-7 show the M973 loaded on the M172A1 semitrailer.
- b. *Materials.* Adequate blocking and tiedown materials are provided by the shipping activity (table 5-3).
- c. *Loading.* The M973 may be driven onto the M172A1 by use of the trailer ramps or a suitable substitute. Once the M973 is in position, the transmission control must be placed in neutral. Parking brakes must be set.
- d. *Tiedown.* Figures 5-5 and 5-6 show the M973 blocked and tied down on the M172A1 semitrailer. Figure 5-7 is a diagram of the shoring required for the M172A1 semitrailer, and figure 5-8 is a turning diagram for the M172A1 semitrailer. Tables 5-3 and 5-4 are the bill of materials and application of materials used for blocking and tiedown of the M973 on the M172A1 semitrailer.

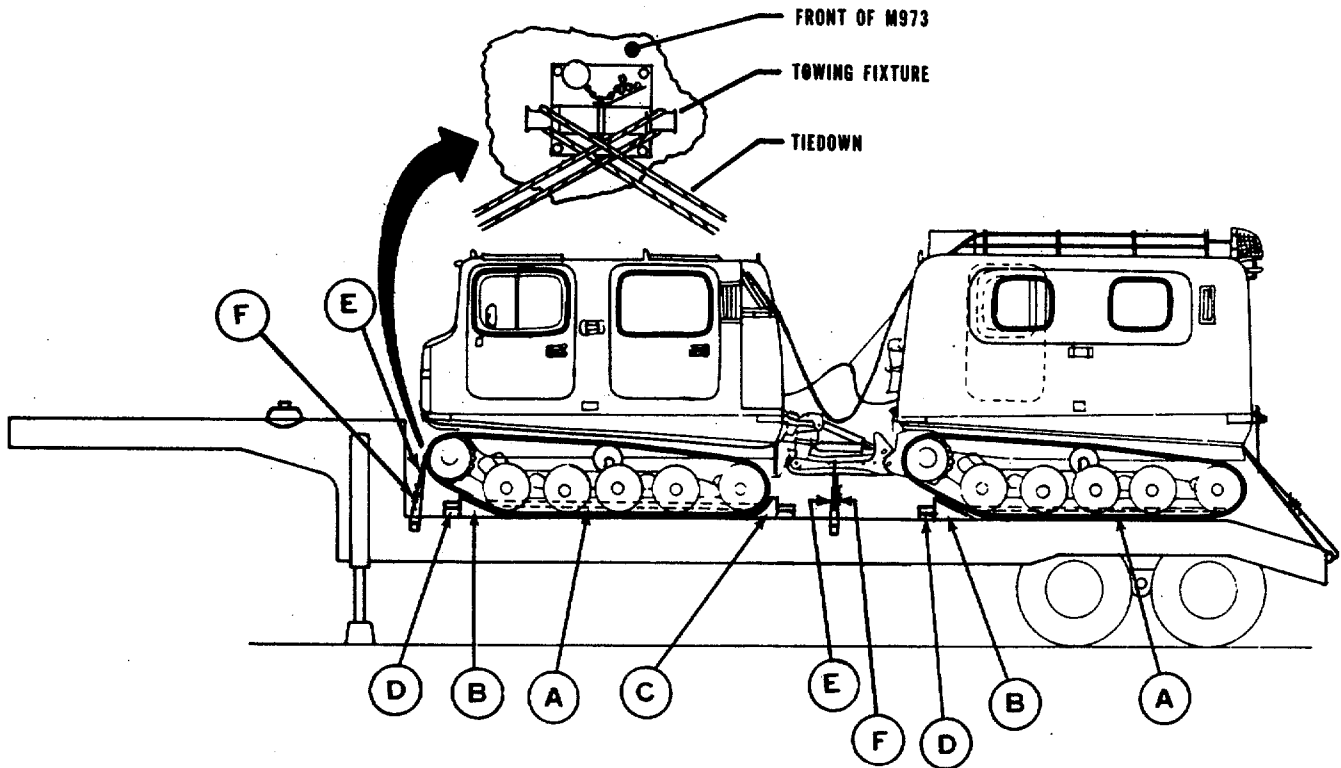

Figure 5-5. Side elevation, tiedown of the M973 on the M172A1 semitrailer.

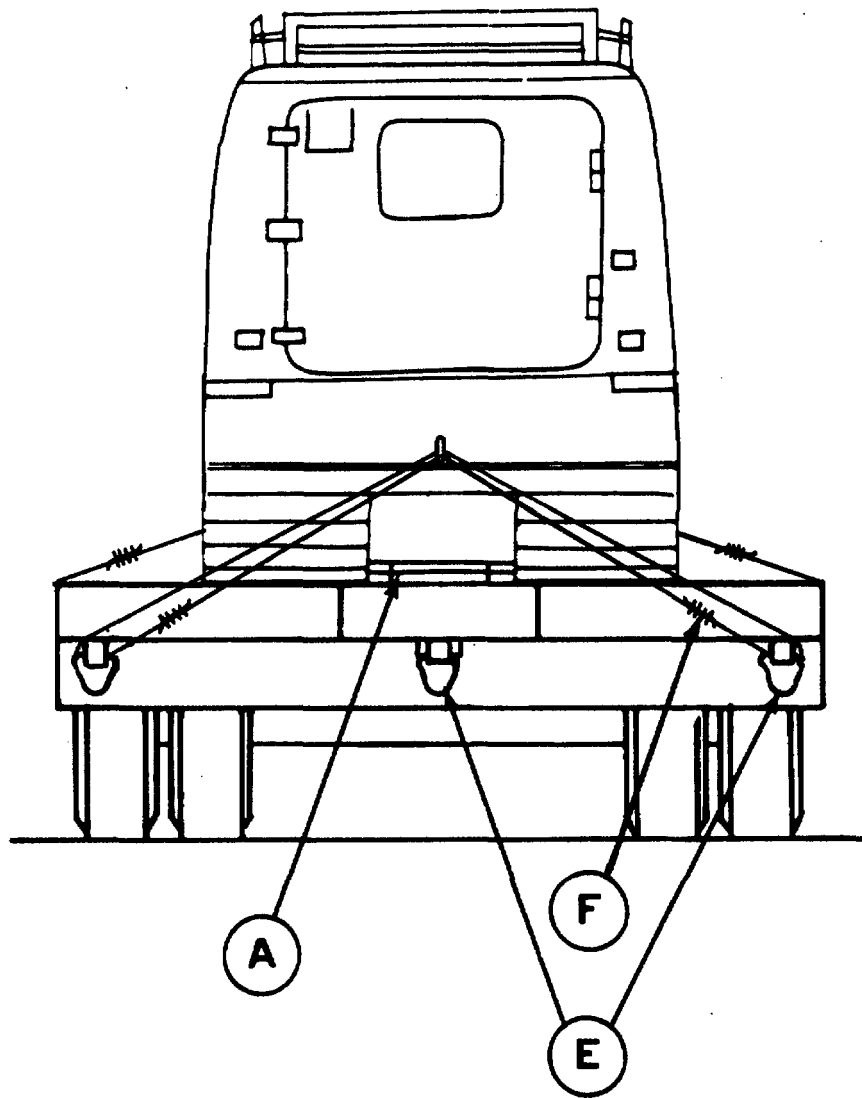

Figure 5-6. End elevation, tiedown of the M973 on the M172A1 semitrailer.

Table 5-3. Bill of Materials for Blocking and Tiedown of the M973 on the M172A1 Semitrailer (Figs 5-5, 5-6, and 5-7).

Item	Description	Approximate Quantity
Lumber	Douglas-fir or comparable, straight-grain, free from material defects; Fed Spec MM-L-71:	
	2- x 4-inch	2 linear ft
	2- x 6-inch	100 linear ft
Nails	2- x 10-inch	40 linear ft
	Common, steel; flathead, bright or cement-coated, type II, style 10; Fed Spec FF-N-106: 12d	270
Wire rope*	20d	100
	6 x 19 IWRC; improved plow steel; preformed, regular-lay; table X, Fed Spec RR-W410: ½ inch	160 ft
Clamps*	Wire rope, U-bolt clips, saddled, single-grip, forged steel, Crosby heavy-duty or equal; Fed Spec FF-C450: ½-inch	20

*Chains and loadbinders may be substituted.

CAUTION: AVOID HITTING METAL FRAME MEMBERS OF SEMITRAILER WITH NAILS.

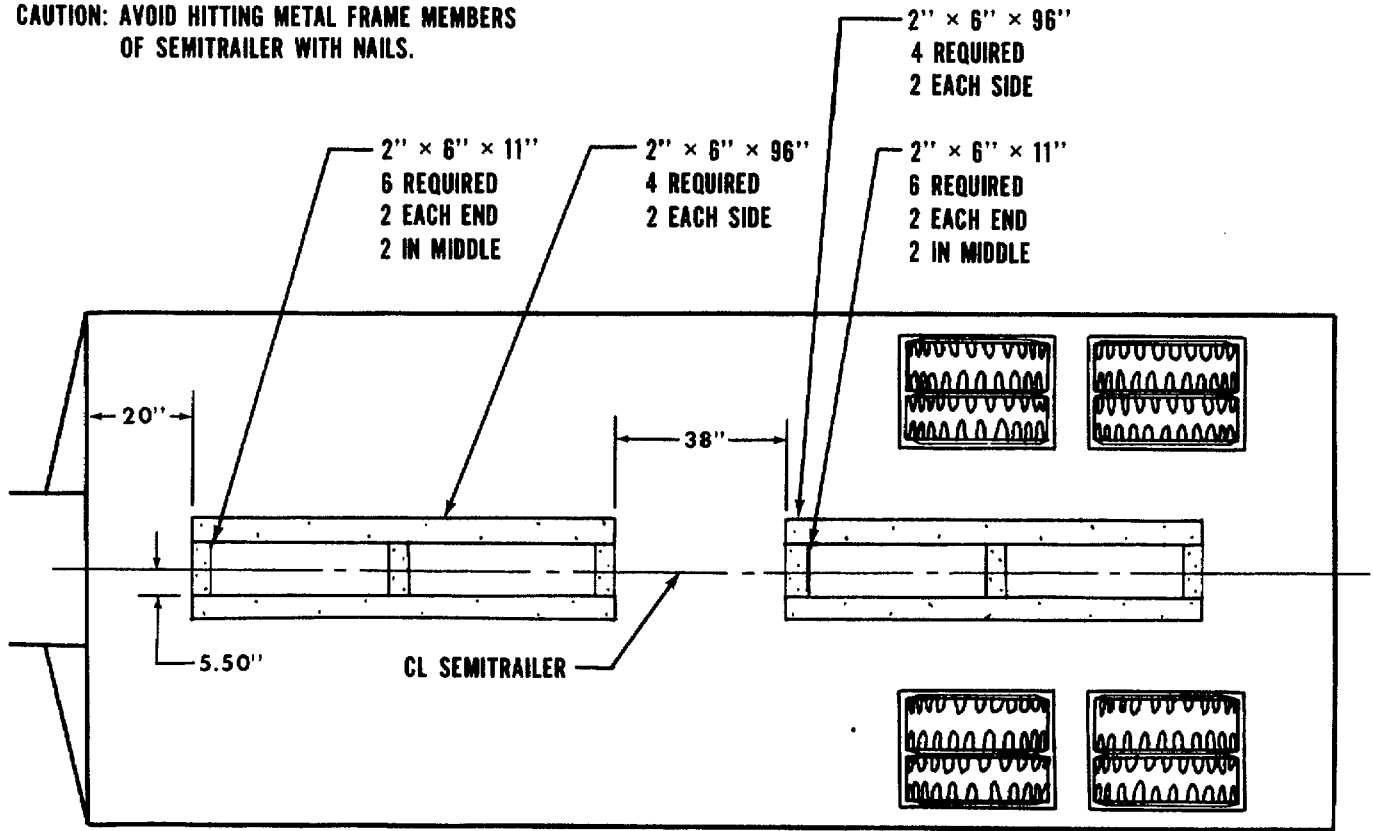

NOTE: SECURE THE FIRST LAYER TO THE WOODEN DECK OF THE SEMITRAILER USING 12d NAILS IN A STAGGERED PATTERN. (THE FIRST AND SECOND LAYERS OF 2 x 6 IN LUMBER FORM THE H-FRAME BETWEEN THE TRACKS OF THE M973.) NAIL THE SECOND LAYER TO THE ONE BELOW USING 20d NAILS IN A STAGGERED PATTERN.

Figure 5-7. Placement of shoring on the M172A1 semitrailer before the M973 is loaded.

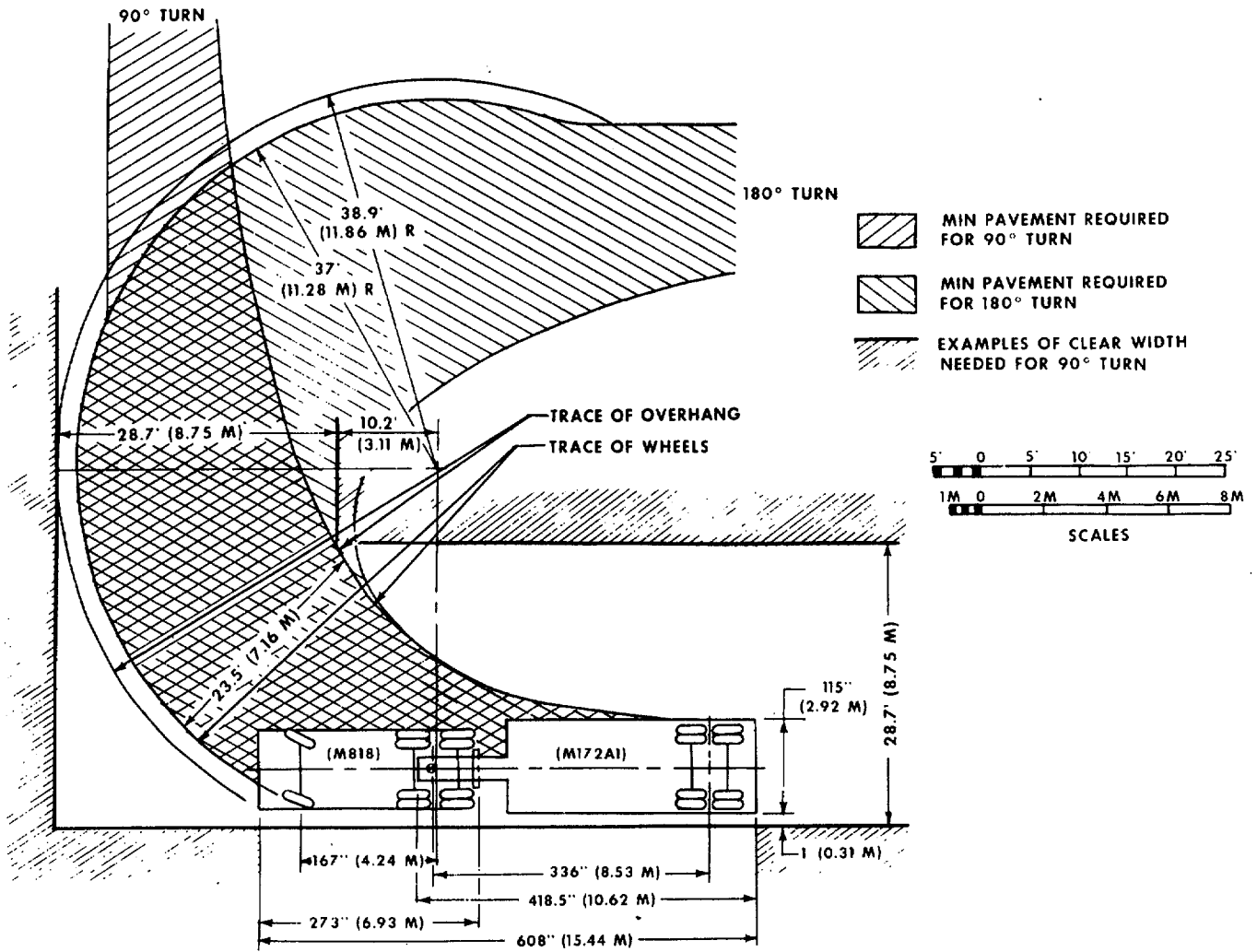

Figure 5-8. Turning diagram for M973 on M172-series semitrailer towed by M818 tractor.

Table 5-4. Application of Materials for Blocking and Tiedown of M973 on the M172A1 Semitrailer
(Figs 5-5, 5-6, and 5-7)

Item	No. Required	Application
A	2	H-frame bracing (figs 5-5 and 5-7). Each layer consists of three pieces of 2- x 6- x 11-inch lumber and two pieces of 2- x 6- x 96-inch lumber. Place the first piece of 11-inch lumber 20 inches from the forward end of the trailer with one end 5.5 inches from the centerline of the trailer. Nail to the trailer with four 12d nails. Place the second piece (centered) 4 feet from the forward side of the first piece. Place the third piece so that the aft edge is 8 feet from the forward edge of the first piece. Nail each with four 12d nails. Place one piece of c96inch lumber against the ends of the 11- inch pieces and nail each with sixteen 12d nails. Repeat for the second layer, except nail with 20d nails. Build the second H-frame so that the forward end is 88 inches from the aft end of the forward H-frame. Load the M978.
B	4	Forward track chocks (detail 4, fig 5-3). Each consists of five pieces of 2 x 10-inch lumber nailed together with 12d nails. Place one chock firmly against each track at the forward end of each unit. Toenail with three 20d nails in each side.
C	4	Rear track chocks (detail 5, fig 8-3). Each consists of five pieces of 2- x 10-inch lumber nailed together with 12d nails. Place one chock firmly against each track at the rear end of the forward unit. Toenail with three 12d nails in each side.
D	8	Backup cleats. Use two pieces of 2- x 6- x 12-inch lumber. Place against the heel of each track chock, items B and C. Nail the lower piece with four 12d nails and the top piece with four 20d nails.
E*	8	Wire rope (detail 3, fig 5-3). Each consists of ½-inch wire rope, length as required. Form a complete loop between the tiedown point on the M973 and the tiedown fitting on the trailer. CAUTION Tension tiedowns evenly. Do not exceed 400 pounds of tension on any single tiedown. (Wire rope ends should overlap a minimum of 20 inches.) Secure with four ½-inch clamps (item F).
F*	32	Clamps, ½-inch (detail 3, fig 5-8). Place four clamps on each wire rope loop at the overlap area and space each clamp 2-1/2 inches apart, with a minimum of 6 inches from the free end of the wire rope. Tension wire rope and tighten clamps from 20- to 25-foot-pound torque.

*Chains and loadbinders may be substituted.

**CHAPTER 6
MARINE AND TERMINAL TRANSPORTABILITY GUIDANCE**

Section I. GENERAL

6-1. Scope

This chapter provides transportability guidance for marine and terminal movement of the M973. It covers significant technical and physical characteristics, as well as safety precautions; prescribes materials; and provides guidance required to prepare, lift, tie down, and discharge this vehicle.

6-2. Safety

In addition to the safety precautions in chapter 3, the following should be noted:

- a. The activity offering the vehicle for transport will notify the carrier if ammunition (or explosives) is to be transported with the vehicle. Compliance with AR 55-228, paragraph 2-7, is mandatory.
- b. Ammunition and vehicles will be handled and stowed in accordance with provisions contained in Code of Federal Regulations (CFR) 49 or reissues thereof.
- c. Fire extinguishers must be available during all loading and discharge operations.
- d. Vessel equipment and gear should be inspected before being used.
- e. Personnel should be cautioned not to walk under items being lifted.
- f. Lifting eyes, shackles, and slings should be inspected to insure that they are complete and not damaged.
- g. All lifts should have at least two tag lines attached to control the swing of the lift while suspended.
- h. Check to insure that lifting eyes are screwed all the way in (shoulder flush with the roof of vehicle) and cannot be loosened by hand.

WARNING

The articulated steering unit must be locked with the steering ram locks before attempting to lift the M973.

6-3. Marine Shipment

The M973 can be transported by a variety of inland waterway cargo vessels, by lighters, and by most sea-going cargo vessels.

NOTE

The methods described in this chapter for lifting and securing are suggested procedures. Other methods of handling and stowage may be used provided that they will insure safe delivery without damage.

Section II. LOADING AND SECURING

6-4. General Rules

a. *Stowage.* Below-deck stowage should be provided whenever possible. In general, good stowage means placing the carriers as close together as practical, with minimum space between the outer item and the sweatboards (about 4 to 6 inches). The M973 is secured by adequate blocking and lashing. Securing includes blocking of tracks on all four sides so that the M973 cannot move in any direction; bracing of individual blocks to bulkheads, stanchions, and other vehicle blocks; and lashing of the M973 with wire rope, chain, or patented lashings. Breakable parts should be protected; spare parts should be stowed in or near the parent item; brakes should be set; and the transmission control should be placed in neutral.

b. *Lifting.* Correct lifting points on the carriers are the lifting eyes located at the upper four corners of each car (total of eight). A typical lifting diagram is shown in figure 6-1.

c. *Loading.* The M973 will be loaded on seagoing cargo vessels in its minimum configuration as described in paragraph 2-4. It may be loaded under its own power or by cranes of adequate capacity aboard landing craft, beach discharge lighters, heavy and medium amphibious lighters, and landing ships. It can also be driven or towed aboard roll-on/roll-off vessels, or onto the decks of barges from a pier, when tidal conditions are suitable and ramps are available. The M973 can be loaded onto seagoing vessels by shoreside or floating cranes or by heavy-lift ship's gear.

d. *Lighterage.* When transporting the M973 by lighter to or from vessels, blocking will be required. When transporting the M973 by lighter over extended distances or through rough water, tiedowns must also be used.

NOTES:

**EIGHT SLING LEGS, 3/8" DIA,
6×19, IWRC; WIRE ROPE; IMPROVED
PLOW STEEL, TABLE X, FED SPEC RR-W-410**

**EIGHT ANCHOR SHACKLES, SCREW PIN,
5/8, TYPE IV, CLASS 1; TABLE XXV,
FED SPEC RR-C-271**

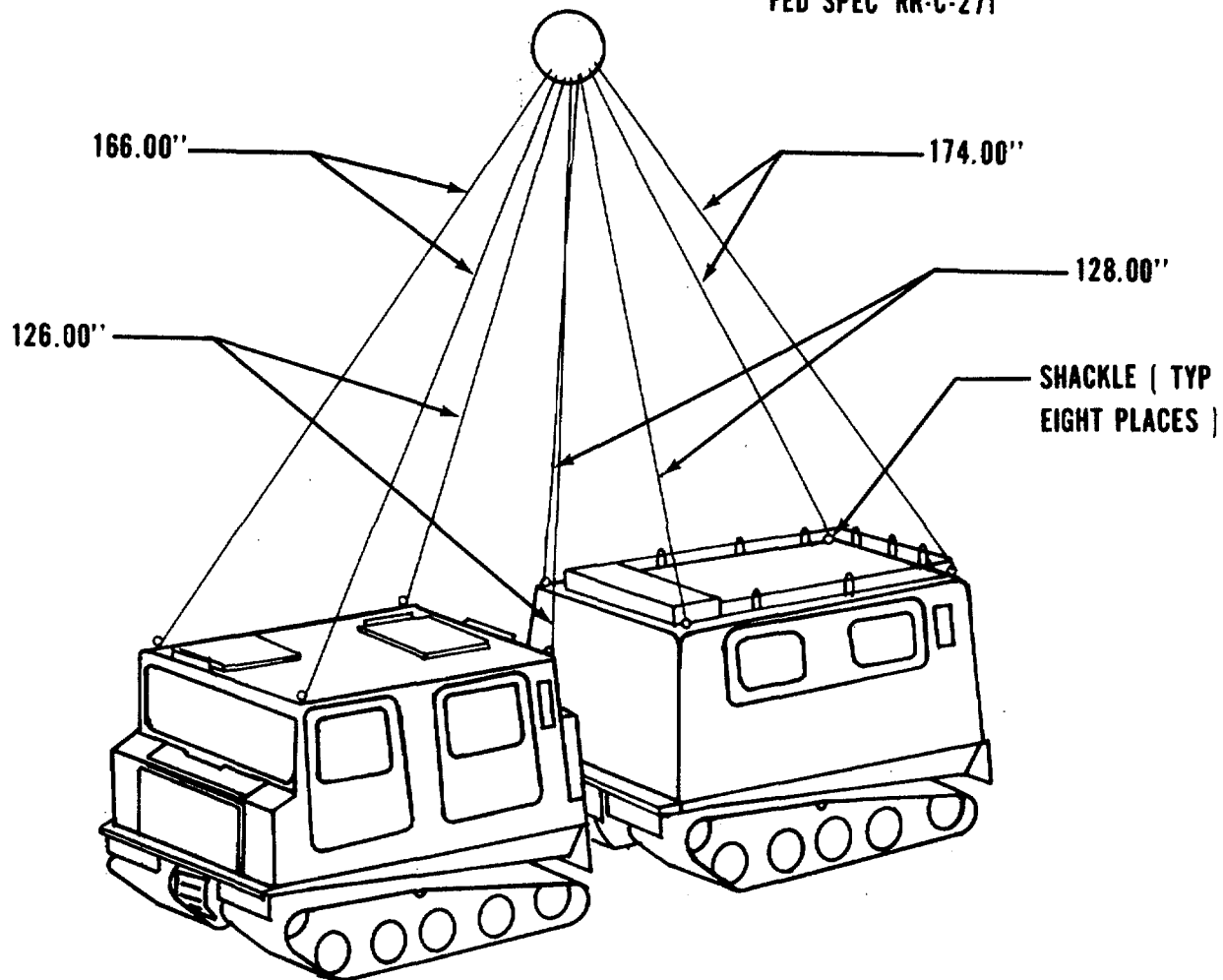

Figure 6-1. Lifting diagram for the M973, using an eight-legged sling.

6-5. General Cargo and Barge-Type (LASH or SEABEE) Ships

NOTE

The fuel tanks must be drained; the battery cables must be disconnected from the batteries; and the cable clamps or connectors must be taped.

a. *Securing.* The M973 must be secured by blocking the tracks with timbers at the front and rear and on both sides. The bracing timbers are force-fitted to a bulkhead, stanchion, or the blocking of an adjacent vehicle. The M973 must be lashed with turnbuckles and wire rope from the vehicle tiedown fittings to the bulkheads, stanchions, or deck fittings (such as pad-eyes or D-rings). Figure 6-2 shows typical blocking and tiedown details. Table 6-1 lists the materials for blocking and tiedown, and table 6-2 explains how to apply these materials.

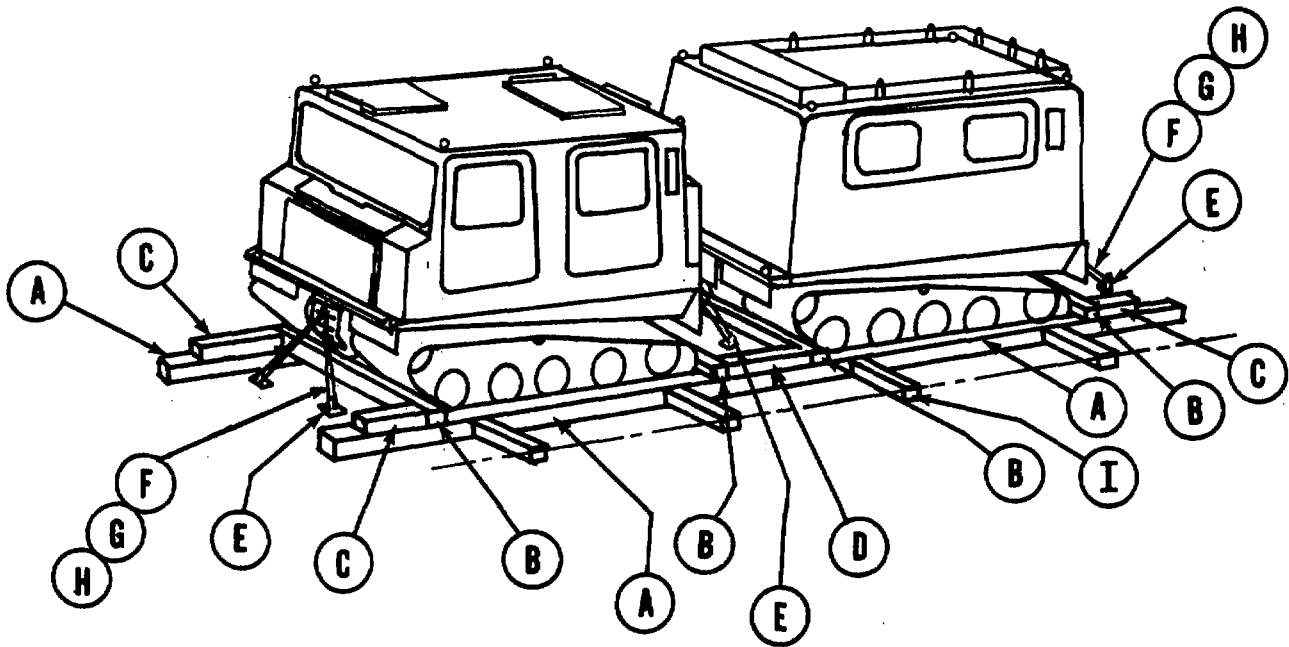

Figure 6-2. Blocking and tiedown on the M973 in a general cargo vessel.

b. *Stowing in Barges.* Figure 6-3 shows a typical loading arrangement for stowing M973's on a LASH barge for transport on a barge-carrying ship. Loading and blocking and bracing must proceed from the outer areas of the barge toward the center, which is loaded last. Since barge stability is noticeably affected by the loading of heavy items, the M973's should be loaded symmetrically (front to rear as well as side to side) to keep the barge as level as possible at all times. Variations in centers of gravity may be counterbalanced by loading vehicles alternately, facing forward and aft or head to tail. Blocking should be installed as a separator between the tracks and barge bulkheads, between adjacent rows of M973's, and at the front and rear of the tracks. The bracing timbers must be force-fitted (wedged) to the bulkhead and to the blocking of adjacent vehicles. After the last M973 is loaded, any void area remaining in the center of the barge must be filled by blocking and force-fitted bracing. Blocking and tiedown materials are listed in table 6-1.

Table 6-1. Bill of Materials for Blocking and Tiedown of the M973 in a General Cargo Vessel (Fig 6-2).

Item	Description	Approximate Quantity
Lumber	Douglas-fir or comparable, straight-grain, free from material defects; Fed Spec MM-L-751: 2 x 4-inch 4- x 6inch	2 linear ft 100 linear ft
Nails	Common, steel; flathead, bright or cement-coated, type II, style 10; Fed Spec FF-N-105: 40d	92
Wire rope	6 x 19 IWRC; improved plow steel; preformed, regular-lay; table X, Fed Space RR-W-410: 1½-inch	50 ft
Clamps	Wire rope, U-bolt clips, saddled, single-grip, forged steel, Crosby heavy-duty or equal; Fed Spec FF-C-450: ½-inch	32
Turnbuckles	¾- x 12-inch, eye and clevis type	5

Table 6-2. Application of Materials for Blocking and Tiedown of the M97s in a General Cargo Vessel (Fig 6-2).

Item No.	Required	Application
A	4	Side blocking. Each consists of 4- x 6 x 144-inch lumber. Locate one piece on each side of each unit against the outside of the tracks. Butt the two pieces on each side in the middle between the two units.
B	4	End blocking. Each consists of 4- x 6- x 84Winch lumber. Locate on top of Item A and against the tracks at the front and rear of each unit. Toenail to Item A with four 40d nails at each end.

Table 6-2 - Continued

Item No.	Required	Application
C	4	Backup cleats. Each consists of 4- x 6- x 12-inch lumber. Locate on top of item A against item B. Nail to item A with 40d nails.
D	2	Backup cleats. Each consists of 4- x 6-inch x length-to-suit lumber. Locate on top of item A between the two item B's. Nail to item A with six 40d nails.
E	6	Padeyes. Built into vessel deck.
F	5	Turnbuckles, 3/4- x 12-inch eye-and-clevis type. Attach clevis end to item E.
G	as required	Wire rope. Make a complete loop through the turnbuckle eye fitting and the opposite side of the front units' forward tiedown fixture. Repeat for the other forward tiedown. Place one complete loop from the left side tiedown over the lower support arms, between the units, to the turnbuckle eye fitting on the right side. Secure a 2- x 4- x 10-inch wooden block between the wire rope and the support arms so that the wire does not contact the support arms when wire is tensioned. Form a complete loop through the turnbuckle eye fitting and the rear units' pintle. Repeat for the other rear tiedown. Tension all tiedowns evenly.
CAUTION		
H	32	Tension tiedowns evenly. Do not exceed 400 pounds of tension on any single tiedown.
I	as required	Clamps, 3/8-inch. Use four to secure each item G. Bracing. Each consists of 4- x 6-inch x length-to-suit lumber. Brace as required against adjacent vehicle, cargo, or side of vessel bulkhead. Secure each piece to adjacent blocking or bracing by toenailing with four 40d nails.

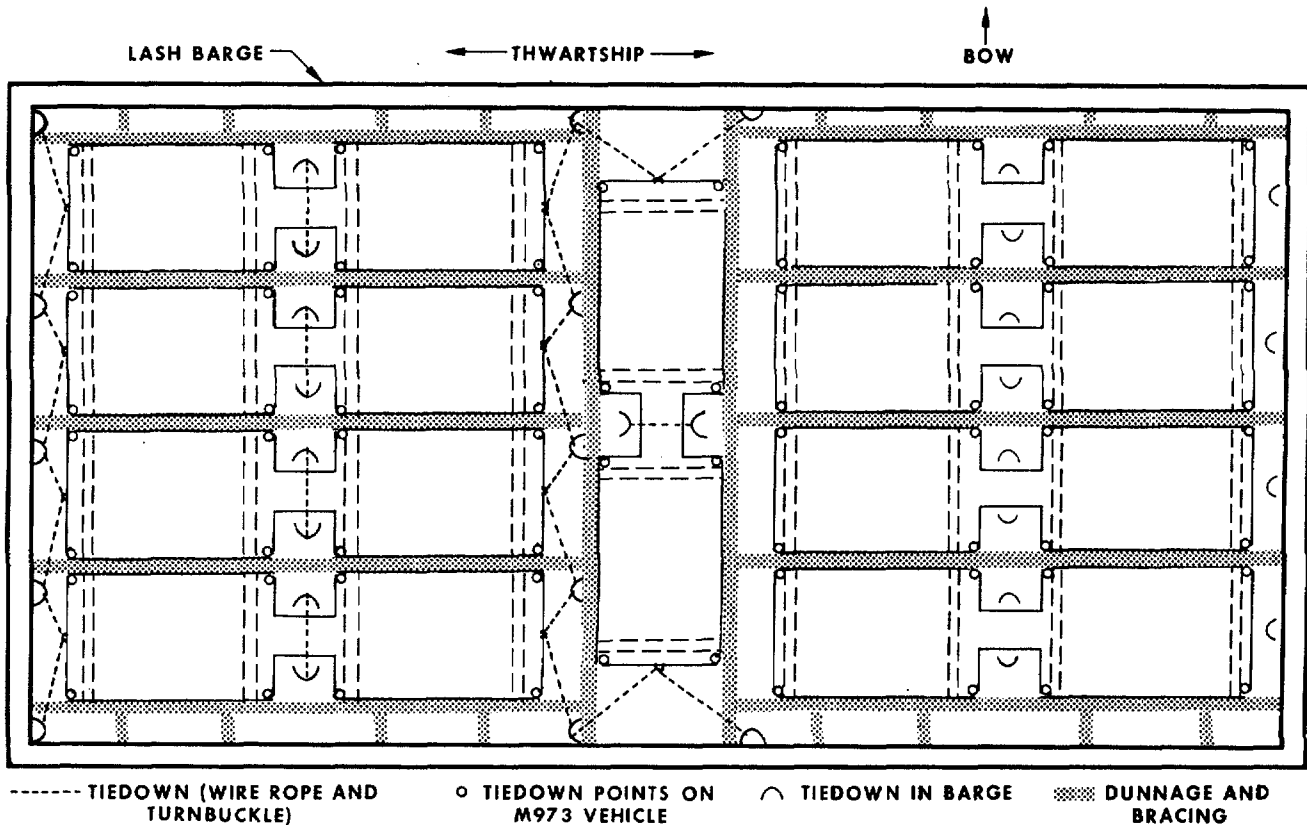

Figure 6-3. Typical loading of M973 vehicles on a LASH (59.9feet by 29.5 feet), using wire rope, cable clips, and turnbuckles with blocking between vehicles and between vehicles and hull.

6-6. Roll-On/Roll-Off (RORO) and Seatrain Vessels, Landing Ships, and Attack Cargo Ships

NOTE

When the M973 is loaded on vessels that are adequately ventilated with power blowers, such as RORO vessels, the fuel need not be drained nor the batteries disconnected.

a. *Loading.* The M973 can be loaded under its own power or towed aboard vessels having roll-on capability.

b. *Securing.* RORO and Seatrain vessels, landing ships, and attack cargo ships are equipped with patented lashing gear (equipment made by Peck and Hale is often used) and permanent fittings in the deck. Eight Peck and Hale lashings, size 4M (4,200-lb breaking strength), should be used to tie down each M973, two lashings, crossed, from the forward tiedown points and two lashings, crossed, from the aft tiedown points of each unit to the "cloverleaf" deck sockets or bulkhead fittings. Blocking and bracing is not required with adequate patented lashing gear (see fig. 6-4)

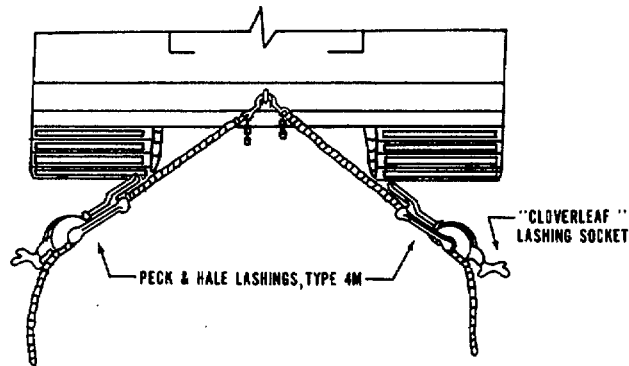

Figure 6-4. Rear view of the M973 tiedown on a RORO ship, showing typical securement with Peck and Hale lashings.

CHAPTER 7
RAIL TRANSPORTABILITY GUIDANCE
Section I. GENERAL

7-1. Scope

This chapter provides transportability guidance for rail movement of the M973. It covers significant technical and physical characteristics as well as safety considerations; prescribes materials, and provides guidance required to prepare, load, and tie down the M973 on flatcars.

7-2. Maximum Utilization of Railcars

Additional cargo, as approved by the activity offering the M973 for transport, may be transported with the M973.

Section II. TRANSPORT ON CONUS RAILWAYS

7-3. General

The transportability guidance contained in this section is applicable when the M973 is transported on CONUS railways. Consideration is given to single and multiple movements on railcars normally used for this type of equipment. The M973 can be transported without restriction and without sectionalization or major disassembly.

7-4. Preparation

Remove the basic Issue Items from the outside of the M973 and stow them securely inside the cab of the M973.

CAUTION

Once the M973 is in the tiedown position, lock the articulated steering unit with the steering cylinder locks.

7-5. Loading on General Purpose Flatcars.

a. The M973 can be placed in the tiedown position on a railcar by a crane of adequate capacity or it may be driven or towed onto the railcar provided that a suitable ramp is available. Lifting is discussed in paragraph 6-2.

CAUTION

Do not allow the M973 to exceed 3 miles per hour during loading or unloading operations.

b. The load illustrated in figure 7-1 and 7-2 is based on a flatcar of 8 feet or more. Figure 7-3 shows the M973 blocking and tiedown details. Table 7-1 is a bill of materials, and table 7-2 is the application of materials for securing the M973 on general purpose flatcars.

NOTE

A staggered nailing pattern should be used when lumber or laminated lumber is nailed to the floor of a railcar. The nailing pattern for an upper piece of lumber should be adjusted so that a nail will not be driven into or against a nail in a lower piece of lumber.

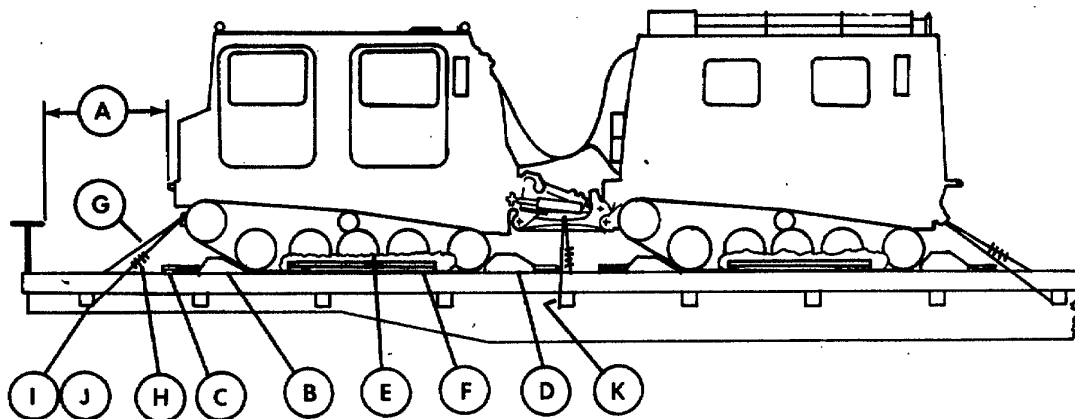

Figure 7-1. Side elevation, tiedown of the M973 on a general purpose flatcar.

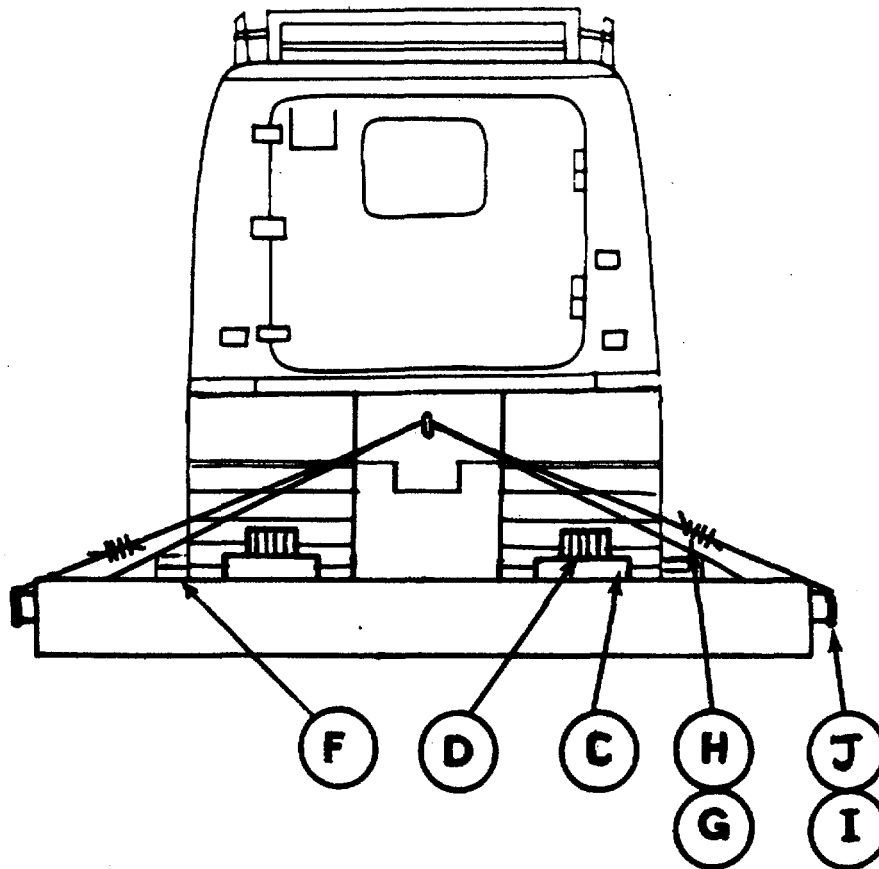

Figure 7-2. End elevation, Tiedown of the M973 on a general purpose flatcar .

Table 7-1. Bill of Materials for Blocking and Tiedown of the M973 on a CONUS General Purpose Flatcar (Figs 7-1, 7-2, and 7-3).

Item	Description	Approximate Quantity
Lumber	Douglas-fir or comparable, straight-grain, free from material defects; Fed Spec MM-L-751:	
	2- x 4-inch	14 linear ft
	2- x 6-inch	100 linear ft
	2- x 10-inch	40 linear ft
Nails	Common, steel; flathead, bright or cement-coated, type II, style 10; Fed Spec FF-N-105:	12d270
		30d 100
Wire rope	6 x 19 IWRC; improved plow steel; preformed, regular-lay; table X, Fed Spec RR-W-410:	1/2 inch 125 ft
Clamps	Wire rope, U-bolt clips saddled, single-grip, forged steel, Crosby heavy-duty or equal;	
	Fed Spec FF-C-450	1/2-inch 20
		5/8-inch 6
Thimbles	Standard, open-type, 1/2-inch	6

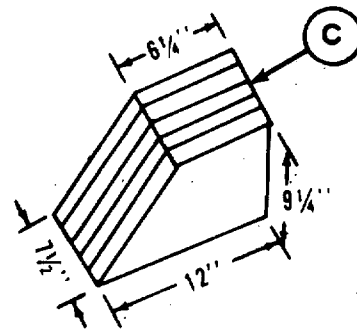
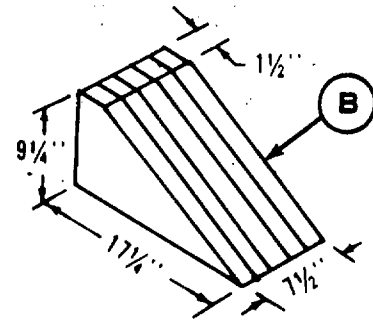
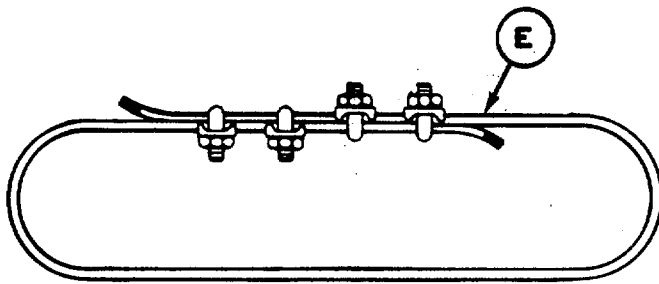
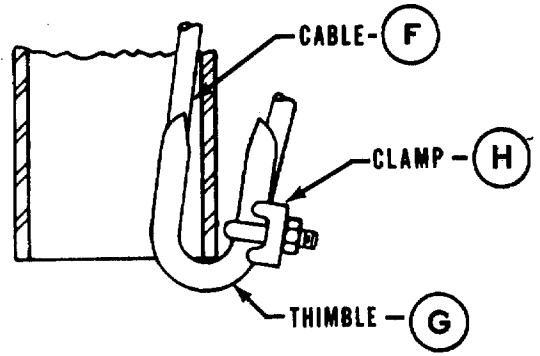
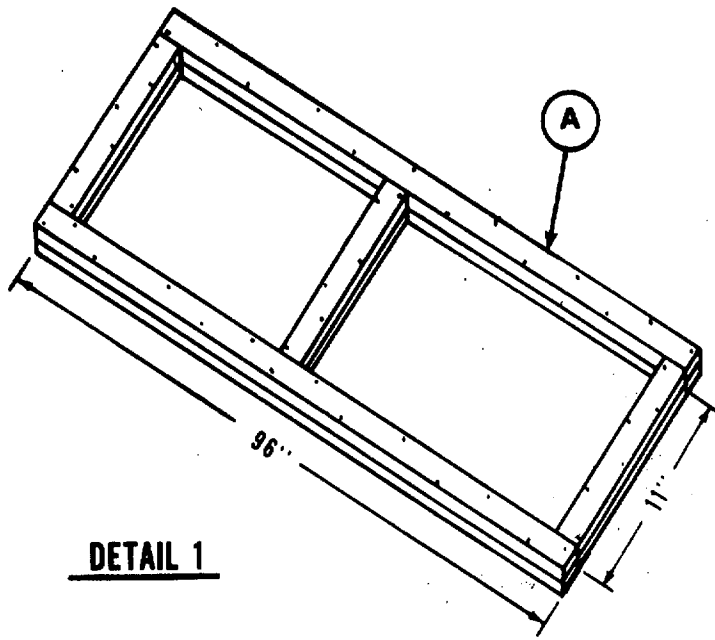

Figure 7-3. Blocking and tiedown details.

Table 7-2. Application of Materials for Blocking and Tiedown of the M973 on a General Purpose Flatcar (Figs 7-1, 7-2, and 7-3).

Item	No. Req.	Application
A		<i>Brake wheel clearance.</i> Minimum clearance required is 6 inches above, in back of, and on both sides of, and 4 inches underneath wheel (figure 7-1).
B	4	<i>Forward track chocks (detail 2, fig 7-3).</i> Each consists of five pieces of 2- X 10-inch lumber nailed together with 12d nails, or pieces may be cut from 8- X 10-inch lumber. Solid chocks cut from 8- X 10-inch lumber are required by Alaskan railroads. Place one chock firmly against the center of each track at the forward end of each unit. Toenail with three 30d nails in each side.
C	8	<i>Backup cleats.</i> Use two pieces of 2- X 6- X 18-inch lumber. Place against the heel of each track chock, items B and D. Nail the bottom pieces with three 30d nails.
D	4	<i>Rear track chocks (detail 3, fig 7-3).</i> Each consists of five pieces of 2- X 10-inch lumber nailed together with 12d nails or pieces may be cut from 8- X 10-inch lumber. Solid chocks cut from 8- X 10-inch lumber are required by the Alaskan railroads. Place one chock firmly against the center of each track at the aft end of each unit. Toenail with three 30d nails in each side.
E	4	<i>Barrier material.</i> Place barrier material on the railcar and against the tracks.
F	4	<i>Side blocking.</i> Each consists of two 2- X 4- 72-inch lumber. Place on top of and against barrier material and firmly against the track. Nail the bottom pieces with ten 30d nails and the top piece with ten 30d nails.
G	5	<i>Wire rope (detail 4, fig 7-3).</i> Each consists of ½-inch wire rope, length as required. Form a complete loop between the front units' forward tiedown fixture and the right stake pocket on the flatcar. Form a complete loop between the front units' forward tiedown fixture and the left stake pocket on the flatcar. Place one complete loop from the left stake pocket on the flatcar over the lower support arms between the units, to the right stake pocket on the flatcar. Secure a 2- X 4- X 10- inch wooden block between the wire rope and each support arms so that the wire does not contact the support arms when wire is tensioned. Form a complete loop between the rear units' pintle and the right stake pocket on the flatcar. Form a complete loop between the pintle on the left stake pocket of the flatcar. Tension all tiedowns evenly and secure with four cable clamps, item H.
H	20	<i>Clamps (detail 4, fig 7-3).</i> Place four ½-inch clamps on each wire loop at the overlap area and space each clamp 3 inches apart, with a minimum of 6 inches from each end of the wire rope. After placement of thimble (item I) at the stake pocket, tension wire rope and tighten clamps from 20- to 25-foot-pound torque.
I	6	<i>Thimbles (detail 5, fig 7-3).</i> Place one ½-inch thimble between the wire rope and the stake pocket and secure with item J.
J	6	<i>Clamps (detail 5, fig 7-3).</i> Secure each ½-inch thimble with one 5/8-inch clamp.

GENERAL INSTRUCTIONS

1. Wooden blocks (2- X 4- X 10-inch) must be used to protect the support arms of the articulation drive assembly between the two units of the M973. Secure wire rope to wooden block by driving a 12d nail half way and bending the nail over the wire rope until the head of the nail contacts the wood.
2. Tensioning of wire rope can be accomplished with an applicable sized come-along mechanical hoist or equal tensioning device.
3. When the M973 is in the tiedown position, place the transmission control in neutral and set parking brakes.
4. Loading Rules 1A, 2, 3, 4, 5, 9, 14, 15, and 19A in Section No. 1 of the *Rules Governing the Loading of Commodities on Open-Top Cars and Trailers*, published by the Association of American Railroads, provide applicable guidelines and are mandatory in application.

Section III. TRANSPORT ON FOREIGN RAILWAYS

7-6. General

The transportability guidance contained in this section is applicable when the M973 is transported on foreign railways. Consideration is given to single and multiple movements on the types of railcars normally used for the transport of this type of vehicle. The M973, when loaded on a suitable flatcar, can be transported, with restrictions, within European countries complying with the passe-partout international (PPI) gauge railways. Because of the various designation systems used by different countries, foreign railcars are difficult to classify. In addition, clearances may vary between countries and within a country. Consequently, evaluation of transport capability must be made on an individual basis.

7-7. Transport on Foreign Service Flatcars

The M973 can be transported on a number of foreign service flatcars. The materials required for blocking and tiedown on foreign service flatcars are essentially the same as those used in CONUS. Dimensions, load capacity, and other data for several flatcars available in Europe, as well as detailed guidance for securing vehicles on these cars, are contained in 4TH TRANSCOM Pamphlet 55-2, Tiedown Guide for Rail Movements, 15 May 1982.

**APPENDIX
REFERENCES**

A-1. Army Regulations (AR)		55-405-9	Army Aviation Maintenance Engineering Manual: Weight and Balance
55-29	Military Convoy Operations in CONUS		
55-80	Highways for National Defense	55-500	Marine Equip. Characteristics and Data
55-162	Permits for Oversize, Overweight, or Other Special Military Movements on Public Highways in the United States	55-1520-217-10-1	Operators Manual: Army Model CH-54A Helicopter
55-228	Transportation by Water of Explosives or Hazardous Cargo	55-1520-217-10-2	Operators Manual: Army Model CH-54B Helicopter
55-355	Military Traffic Management Regulation	55-1520-227-10	Operators Manual: Army Model CH-47D Helicopter
70-44	DOD Engineering for Transportability	55-2200-001-12	Transportability Guidance for Application of Blocking, Bracing, and Tiedown Materials for Rail Transportation
385-40	Accident Reporting and Records		
746-1	Packaging of Army Material for shipment and Storage		
A-2. Field Manuals (FM)			
55-9	Unit Air Movement Planning		
55-15	Transportation Reference Data		
55-17	Terminal Operations Coordinator's Handbook		
A-3. Supply Bulletins (SB)			
700-20	Army Adopted/Other Items for Authorization/List of Reportable Items		
A-4. Technical Bulletins (TB)			
55-46-1	Standard Characteristics (Dimensions, Weight, and Cube) for Transportability of Military Vehicles and Other Outsize/Overweight Equipment		
A-5. Technical Manuals (TM)			
9-2350-272-10	Operator's Manual: Small Unit Support Vehicle (SUSV)		
38-250 (AFR 71-4)	Packaging and Materials Handling: Preparation of Hazardous Materials for Military Air shipment		
		A-6. Technical Orders (TO) (Air Force)	
		1-1B-40	Handbook of Weight and Balance Data
		1C-5A-9	Loading Instructions, USAF Series C-5A Airplane
		1C-130A-9	Loading Instructions, USAF Series C-130A Airplane
		1C-141B-9	Loading Instructions, USAF Series C-141B Airplane
		A-7. 4TH TRANSCOM Pamphlet	
		55-2	Tiedown Guide for Rail Movements
		A-8. Other Publications and Source of Procurement	
		a.	Code of Federal Regulations, Title 49- Transportation, Parts 170-179
			Available from: Superintendent of Documents US Government Printing Office Washington, DC 20402
		b.	Association of American Railroads Rules Governing the Loading of Commodities on Open-Top Cars and Trailers Section No. 1 - General Rules Section No. 6 - Rules Governing the Loading of Department of Defense Material on Open-Top Cars

Available from Association of American Railroads
59 E Van Buren Street
Chicago, IL 60605

Available from American Assoc. of State Highway
and Transportation Officials
341 National Press Building
Washington, DC 20004

- c. American Association of State Highway and
Transportation Officials (AASHTO) *Legal
Maximum Dimensions and weight of Motor
Vehicles Compared with AASHTO Standards*
USCG 108 ****

A-9. Department of Transportation
USCG 108 Rules and Regulations for Military Explo-
sives and Hazardous Munitions

By Order of the Secretary of the Army:

JOHN A. WICKHAM, JR.
General, United States Army
Chief of Staff

Official:

MILDRED E. HEDBERG
Brigadier General, United States Army
The Adjutant General

DISTRIBUTION:

To be distributed in accordance with DA Form 12-37, Operators Maintenance requirements for Carrier, Cargo, Tracked, 1-1/2- ton, Small Unit Support Vehicle, (SUSV), M973.

RECOMMENDED CHANGES TO EQUIPMENT TECHNICAL PUBLICATIONS

 <p style="text-align: center;"><i>THEN...JOT DOWN THE DOPE ABOUT IT ON THIS FORM. CAREFULLY TEAR IT OUT, FOLD IT AND DROP IT IN THE MAIL.</i></p>		SOMETHING WRONG WITH PUBLICATION		
		FROM: (PRINT YOUR UNIT'S COMPLETE ADDRESS)		
		DATE SENT		
PUBLICATION NUMBER		PUBLICATION DATE	PUBLICATION TITLE	
BE EXACT PIN-POINT WHERE IT IS				
PAGE NO.	PARA- GRAPH	FIGURE NO.	TABLE NO.	<p style="text-align: center; font-weight: bold;">IN THIS SPACE, TELL WHAT IS WRONG AND WHAT SHOULD BE DONE ABOUT IT.</p>
PRINTED NAME, GRADE OR TITLE AND TELEPHONE NUMBER			SIGN HERE	

DA FORM 1 JUL 79 **2028-2**

PREVIOUS EDITIONS ARE OBSOLETE.

P.S.--IF YOUR OUTFIT WANTS TO KNOW ABOUT YOUR RECOMMENDATION MAKE A CARBON COPY OF THIS AND GIVE IT TO YOUR HEADQUARTERS.

PIN: 058789